

nEXO

AES67

User Manual



IP AUDIO INTERFACE AES67

SAFETY INSTRUCTIONS

Please read these safety instructions carefully.

- 1 Save this user manual for future reference.
- 2 Power connectors must be accessible for disconnection and where people cannot step on or trip. Disconnect the equipment from the AC/DC (AC) outlet before cleaning it.
- 3 The appliance must not be exposed to falling water or splashes and no liquid-filled objects should be placed on the appliance. Do not use liquid or spray detergent for cleaning. Do not expose this equipment to wet areas.
- 4 Bare flame sources, such as burning candles, should not be placed on the appliance.
- 5 Install this equipment on a secure surface. If you do not place the equipment on a safe surface, it may fall and be damaged.
- 6 The roof grilles are used for convection of air. DO NOT COVER THE GRIDS. Leave 5 cm of gap in front and on the sides for proper ventilation.
- 7 Never open the device. For safety reasons, the team should only open it with qualified personnel.
- 8 The equipment must be connected to a protective ground outlet.
- 9 Pay attention to the connection polarity when operating the equipment with a DC (DC) power supply. The reverse polarity connection may cause damage to the equipment, or to the power supply.
- 10 If any of these situations arise, let the technical staff check the equipment:
 - a) The power cord or plug is damaged.
 - b) Liquid has infiltrated the inside of the team.
 - c) The equipment has been exposed to moisture.
 - d) The equipment has not worked well or does not work properly following the instruction manual.
 - e) Equipment has fallen off and is damaged.
 - f) If the equipment has obvious signs of damage.
- 11 Wiring should be done only by trained personnel. Disconnect the audio inputs and outputs while making connections or disconnect the equipment from power. Make sure you use the right cables to make connections.

INDEX

- 1 INTRODUCTION 6**
 - 1.1 System Features 6
 - 1.2 NEXO Hub 6
- 2 DESCRIPTION 8**
 - 2.1 User interface. Frontal..... 8
 - 2.1.1 Buttons 8
 - 2.1.2 Status indicators 9
 - 2.1.3 Input 9
 - 2.2 Back. Inputs and outputs 9
 - 2.2.1 Ethernet Ports 10
 - 2.2.2 MicroSD socket 10
 - 2.2.3 System Integration Ports 10
 - 2.2.4 Audio source inputs and outputs 11
 - 2.2.5 Power supply 12
- 3 INSTALLATION 14**
 - 3.1 Mounting 14
 - 3.1.1 Single-device rack mounting 15
 - 3.1.2 Two-device rack mounting..... 16
 - 3.1.3 Wall Mounting..... 17
 - 3.2 Power management 18
 - 3.3 Connections with NEO+ System..... 18
 - 3.3.1 Flexnet Ring Integration 18
 - 3.3.2 Multi-service network connection 19
 - 3.4 Connection with ONE Systems 20
- 4 ACSINET SYSTEM..... 21**
 - 4.1 ACSINET Domain..... 22
 - 4.2 ACSINET Cluster 22
 - 4.2.1 Cluster Sender 23
 - 4.2.2 Cluster Receivers..... 23
 - 4.3 Virtual Mic 24
- 5 CONFIGURATION. NEXO CONFIG TOOL APP 26**
 - 5.1 Interface 27
 - 5.1.1 Menu Bar 27
 - 5.1.2 Left Panel 27
 - 5.1.3 Center Panel 28
 - 5.2 Device 28
 - 5.2.1 Device info 29

5.2.2	Network.....	29
5.2.3	Device Date & Time	29
5.2.4	Tools.....	30
5.2.5	Live Errors Monitor	30
5.3	Audio Config	31
5.3.1	Inputs	32
5.3.2	Outputs.....	33
5.3.3	ACSINet-controlled channels	34
5.4	DSP Config	35
5.5	ACSI & ACSINet	37
5.5.1	ACSINet Domain Config.....	37
5.5.2	ACSINet Cluster Config.....	38
5.5.3	Local ACSI Bus Config	42
5.5.4	Virtual Mic Mode	45
5.5.5	Zone Monitor Config	47
5.6	I/O Ports.....	48
5.6.1	GPIO Port	49
5.6.2	RS232 Serial Port	49
5.7	Power Config.....	50
5.7.1	Device Power Inputs Configuration.....	50
5.7.2	Emergency Power Supply (EPS).....	50
5.8	AES67 Module	51
5.8.1	PTPv2 Config.....	52
5.8.2	Physical Vumeters [dB].....	52
5.8.3	PTPv2 Runtime Status	52
5.8.4	AES67 Tx Slots	52
5.8.5	AES67 Rx Slots	53
5.8.6	Control.....	53
5.9	Ethernet Monitor	53
5.9.1	Ethernet Switch Ports	54
5.9.2	Processor ENET Rx Stats.....	54
5.9.3	General Info	55
5.10	Log Viewer	55
6	MAINTENANCE INSTRUCTIONS.....	56
7	SPECIFICATIONS	57

Appendix I. Network Configuration..... 58
Appendix II. Network Specifications..... 59
Appendix III. Pinout Bus ACSI 61
Appendix IV. Pinout A1 61

1 INTRODUCTION

The NEXO device is a network audio converter designed for integration into voice communication and evacuation systems, compliant with EN54 standard. This equipment is optimized for integration into advanced IP networks and public address systems, providing high-quality audio transmission and reception.

NEXO is a versatile solution that allows you to extend and manage complex communication systems using advanced protocols such as AES67 and ACSINet, designed to transmit and receive 2x2 channels of high-quality audio (48kHz, 1ms) over IP networks. Its compact design makes it easy to install in both racks and desktops, adapting to the specific needs of each environment.

1.1 System Features

- **High-quality IP audio:** Compatible with the AES67 standard, it allows transmitting and receiving audio in 48kHz sample rate format, at 1 ms per packet and with 24-bit resolution.
- **EN54 certification:** Fully integrated with LDA PA/VA systems, such as NEO+, ensuring compatibility with the EN54-16 standard.
- **Advanced connectivity:** Two RJ-45 Ethernet ports with PoE capability on port A, support for VLANs and compatibility with Flexnet networks to provide optimal connectivity with NEO+ systems.
- **Device expansion:**
 - Connect up to 32 additional devices per unit using the ACSI v2 protocol and its conversion to ACSINet.
 - Global capacity to integrate up to 4096 devices into a NEO+ system, including microphones and emergency panels, via the ACSINet protocol.
- **Integrated DSP:** Digital signal processing with a 2x2 audio matrix and encryption for added security.
- **Control and monitoring:** 8 GPIOs (programmable input and output ports for system events), RS-232 serial connection port for external system integration, and microSD reader for license installation.
- **Compact and versatile design:** Ideal for rack, wall or desktop installations, adapting to different environments and requirements.

1.2 NEXO Hub

NEXO Hub is an advanced version of the NEXO device that allows integration into multi-site environments through the ACSINet Cluster architecture. Its main function is to act as a control and audio gateway between multi-site global microphones and local systems. In NEO+ systems, communication is carried out through the ACSINet Domain, while in ONE system an ACSIV1 gateway to the Site is used, enabling distributed public address management in geographically separated installations.

For more information on its installation and configuration, see chapter 4 ACSINET SYSTEM and 5.5.2 ACSINet Cluster

The NEXO Hub function is implemented after your SD card license is activated (see chapter 2.2.2 MicroSD socket).

Its activation unlocks additional features such as monitoring links between cluster devices, distributing system status information and executing ACSI actions between islands. This architecture facilitates scalable, secure and coordinated management of PA/VA systems.

2 DESCRIPTION

2.1 User interface. Frontal

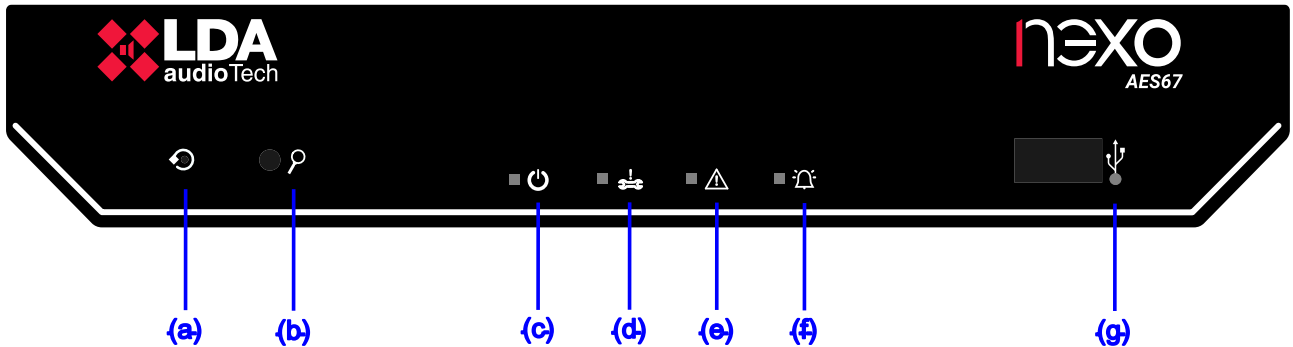

Figure 1: Indicators

	RESET		FAULT
	FIND		EMERGENCY
	POWER		USB
	SYSTEM		

Table 1: Indicators

2.1.1 Buttons

The unit has physical controls that allow the device to be operated manually, being especially useful in maintenance tasks or in specific situations that require direct intervention.

(a)  "RESET"

It allows you to perform two different functions depending on the duration of the press:

- **Short press:** Restarts the device, resetting it to operation without modifying the configured settings.
- **Long Press (5 seconds):** Restores the device to factory defaults. This removes any custom settings and returns the device to its original state.

(b)  "FIND"

It allows two different functions to be performed depending on the duration of the button press:

- **Short press (less than 3 seconds): Find Me function.** It allows locating the device within the LDA Discover Tool v3 or NEXO Config Tool application. The device is highlighted in the app so that it can be easily identified. The LEDs on the front will blink 3 times to indicate that the pulse has been detected.

- **Long press (3 seconds): Link Recovery Mode** function. When the device has enabled the use of VLANs for its communications, it temporarily disables them, allowing you to recover the connection with devices that cannot be accessed from a PC or local network.

The unit will exit this mode and return to its original setting automatically after 60 seconds. Throughout this interval, the LEDs on the front panel will blink.

2.1.2 Status indicators

Status indicators allow you to monitor the operating condition of the equipment or system.

- (c)  "POWER". Green

Power on: The device is properly powered from a valid power source.

- (d)  "SYSTEM". Amber

Power on: Indicates a critical system failure or the NEXO device itself, such as an unexpected device reboot or critical hardware failure that should be considered system issues according to EN54.

- (e)  "FAULT". Amber

Power on: Indicates that the device or system to which it is linked is in a fault state.

- (f)  "EMERGENCY". Red

Available when NEXO is linked to a remote PA/VA system via the ACSINet protocol.

Power on: Indicates that the system is in a state of emergency VA

2.1.3 Input

- (g)  "USB"

The available USB port is reserved for future applications.

2.2 Back. Inputs and outputs

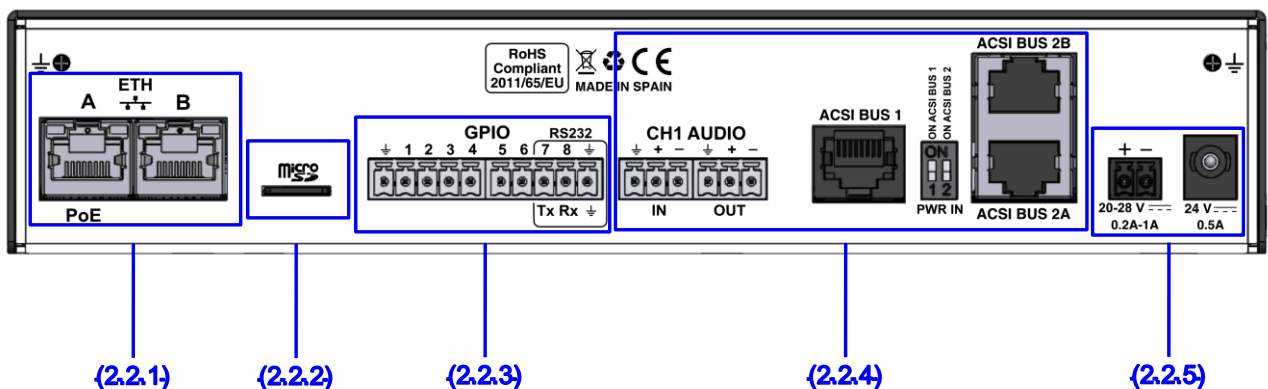

Figure 2: Inputs and outputs

2.2.1 Ethernet Ports

NEXO has two RJ-45 Ethernet ports, designed for connections to IP networks allowing AES67 data and audio transmission. These ports are compatible with Flexnet technology for integration into NEO+ systems, either within the ring or through a multiservice network.

By default, audio and data traffic will be sent without using any VLANs. To enable the use of VLANs and thus enable support for NEXO Flexnet networks, it is required to enable the corresponding option in the configuration section 5.2.2 Network.

For integrations with NEO+, systems see chapter 3.3 Connections with NEO+ System.

NEXO's Ethernet A port supports Power over Ethernet (PoE), which supports the IEEE 802.3af Class 0 standard. The maximum power supported is 12W.

The distance between the device and the PoE switch, or injector should not exceed 100 meters.

The connection is made via CAT6A or higher FTP cable, RJ-45 T568B standard (a connection cable is supplied with the equipment).

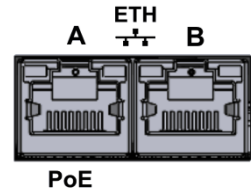

Figure 3: Ethernet Ports

Label	Description	Type	Signals	Activation
A/B	System Connection Ports	Port	Ethernet	Proprietary /AES67 command protocol

Table2: Ethernet Ports

2.2.2 MicroSD socket



NEXO has a microSD slot for the installation of licenses for advanced features, such as NEXO Hub activation.

NEXO Hub functionality allows extending the reach of the system across multi-service networks, maintaining control and audio transmission in multisite architectures.



Figure 5: NEXO Hub License card

Installing licenses in this slot should always be done with the device turned off. Its detection is plug & play, without the need for additional settings for activation.

NOTE: The microSD card is not used for general storage or audio recordings, but exclusively as a secure medium for the activation of licensed functionalities.

2.2.3 System Integration Ports

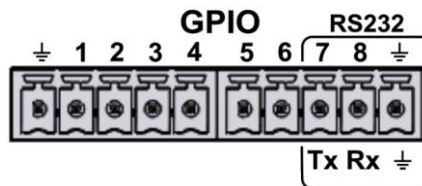

Figure 6: Integration Ports

The connection is made through 2 Euroblock female type connectors with 5 contacts and 3.81 mm pitch (supplied with the equipment). The cable cross-section range for each pole of this connector is: 0.14 → 1.5 mm² (30 → 14 AWG).

(a) GENERAL PURPOSE INPUT OUTPUT (GPIO) PORTS

The device has 8 programmable input and output ports, configurable via the configuration application, for system events (see 5.6.1 GPIO Port). GPIO ports work with TTL level logic signals (0 – 5 VDC).



Figure 7: GPIO

Label	Description	Type	Signals	Activation
GPIO X	Configurable general purpose I/O port	Input Output	\perp x	0-5V DC Input Output 0-5V DC

Table 3: GPIO

(b) INTEGRATION PORT

The device has a two-wire RS232 serial port for the integration of third-party systems.

Default settings for events: 9600 bps, 8 data bits, no parity, 1 stop bit. These values can be changed via the Settings application (see 5.6.2 RS232 Serial Port).

Enabling the RS232 port involves the use of GPIOs 7 and 8.

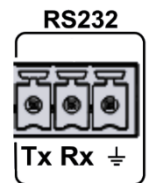

Figure 8: RS232

Label	Description	Type	Signals	Activation
RS232 Tx/Rx	Serial connection port for RS232 integration Tx and Rx terminal	Port	Tx Rx	RS232 Full-Duplex Standard
RS232 \perp	Cable chassis or mesh	NA	NA	NA

Table 4: RS232

2.2.4 Audio source inputs and outputs

NEXO is equipped with two multi-purpose audio channels, named CH1 and ACSI BUS, designed to provide a flexible solution for audio management. Both ports can handle an input channel and an output channel, configuring a total of 2x2 audio channels.

The two channels have a sensitivity of 1 Vrms and operate with balanced audio, enabling high-quality transmission for professional applications and offering greater noise resistance on long wiring lines.

(c) CH1 AUDIO

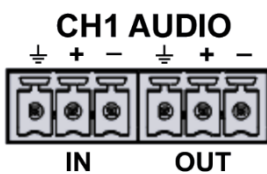

Figure 9: CH1 Audio

The CH1 channel is designed for general audio applications (see 5.3 Audio Config).

The connection is made through 2 female Euroblock connectors with 3 contacts and 3.81 mm pitch, supplied with the equipment. The cable cross-section range for each pole of this connector is: 0.14 → 1.5 mm² (30 → 14 AWG).

Label	Description	Type	Signals	Activation
IN	Line-level balanced audio	Input	\perp + -	NA
OUT		Output		

Table 5: CH1 Audio

(d) BUS ACSI

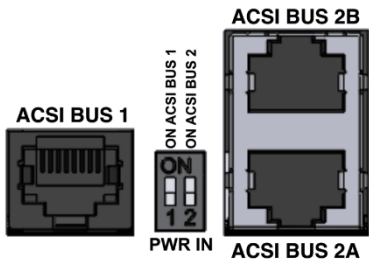

Figure 10: ACSI Bus

The ACSI bus is designed for the connection of up to 32 ACSIv2 devices, such as microphones or emergency panels, for example: MPS8Z, MPS8Z+, VAP-1 and VAP-FES.

This bus combines a balanced line-level audio connection, RS485 serial port for control communications and power lines for ACSIv2 devices.

NEXO has two ACSIv2 ports: the ACSI BUS 1 port, which is factory-enabled for the connection of ACSI v2 microphones, and the ACSI BUS 2 port (A and B), which currently has no ACSI functionality implemented. The use of this port is reserved for future functionality extensions.

NEXO has two ACSI ports for the connection of ACSIv2 microphones:

- ACSI BUS 1. Single-Branch mode. Default function. It is possible to connect a single branch of ACSI microphones in series.
- ACSI BUS 2 (A and B). Dual-branch mode. It is possible to connect two independent branches of ACSI microphones in series.

NOTE: No loop connection should be made between the ACSI BUS 2A and ACSI BUS 2B ports.

Both ports, ACSI BUS 1 AND ACSI BUS 2, cannot be used at the same time for the connection of ACSI microphones. For more information about the configuration of these ports, refer to chapter 5.3.1(b) Input 2: ACSI Bus Analog Audio In.

In addition, these ports can be used as analog audio input and output for more general use. In this way, the ACSI BUS 1 port will be the audio input, and the ACSI BUS 2A port the output in Single-Branch mode, and conversely in Dual-Branch mode, the ACSI BUS 1 port will be the output, and the ACSI BUS 2A port the input.

The connection is made using CAT 5 UTP network cable or higher with RJ-45 T568B standard. The bus supports a maximum connection distance of 1000 m.

For more information on the ACSI bus pinout see Appendix III Pinout Bus ACSI

Label	Description	Type	Signals	Activation
ACSI BUS 1	ACSIv2 Bus port	Input/Output	Protocol	NA
ACSI BUS 2A				
ACSI BUS 2B				

Table 6: ACSI Bus

NOTE: This connection is not compatible with standard Ethernet network electronics.

2.2.5 Power supply

(e) MAIN POWER INPUT

It is the recommended form of power supply for continuous and safe operation.



The connection is made via a standard round power connector (DC jack). The external power supply supplied with the equipment provides 24VDC / 0.5A output.

Figure 11: Main power supply

Label	Description	Type	Signals	Activation
24V	Main power input	Input	NA	24 VDC Current: 0.5 A

Table 7: Main power supply

(f) EMERGENCY POWER INPUT

The device has an emergency power supply input. The emergency voltage is continuous and has a nominal value of 24 VDC, which will be supplied externally to the equipment by a battery source and charger system according to EN 54-4.

The connection is made through a 2-pin female Euroblock connector with a pitch of 3.81 mm supplied with the equipment. The cable cross-section range for each pole of this connector is: 0.14 → 1.5 mm² (30 → 14 AWG).

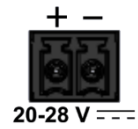

Figure 12: Emergency Power

Label	Description	Type	Signals	Activation
20-28 V	Emergency power input	Input	+ -	20 – 28 VDC Min. current: 0.2 A Max. Current: 1A

Table 8: Emergency Power

(g) PoE POWER INPUT

The device can be powered by Power over Ethernet (PoE), compatible with the IEEE 802.3af Class 0 standard, through Ethernet port A. This power supply allows power to be supplied to the device through a switch or PoE injector compatible with this standard. The maximum power supported by the device via PoE is 12 W.

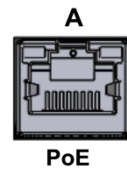

Figure 13: PoE Power

Ethernet port B does not allow the device to be powered via PoE.

The distance between the NEXO device and the switch or PoE injector must not exceed 100 meters. The connection is made using FTP CAT6A cable or higher, with RJ-45 connector and T568B standard.

Label	Description	Type	Signals	Activation
PoE	PoE power input	Input	Ethernet	IEEE 802.3af Class 0 Maximum power: 12 W

Table 9: PoE

3 INSTALLATION

3.1 Mounting

The equipment can be installed in a rack or directly on the wall, depending on the space and needs of the system.

The NEXO device is supplied with the parts required for rack mounting and installation:

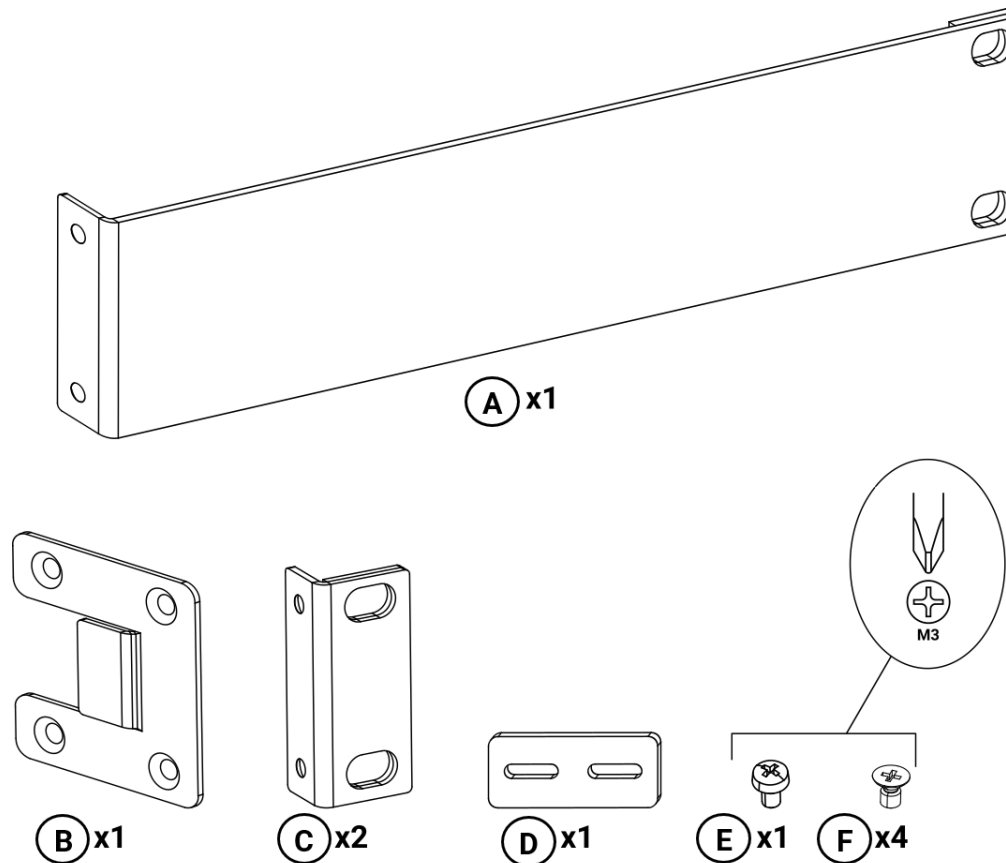

Figure 14: Parts supplied for rack mounting

- A. 1 × Long fixing bracket.
- B. 1 × Side Binding Plate.
- C. 2 × Short fixing bracket.
- D. 1 × Rear Junction Plate.
- E. 1 × M3 pan head screw.
- F. 4 × M3 countersunk screw.

3.1.1 Single-device rack mounting

For rack mounting of a single device, the following parts will be used:

- A. 1 × Long fixing bracket.
- C. 1 × Short fixing bracket.
- F. 4 × M3 countersunk screw.

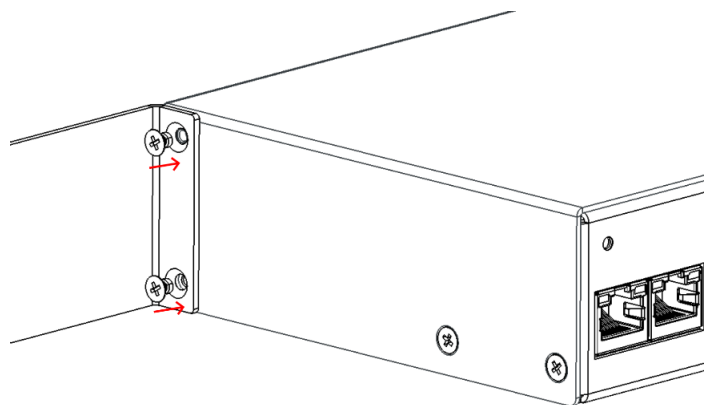

Figure 15: Long fixing bracket assembly

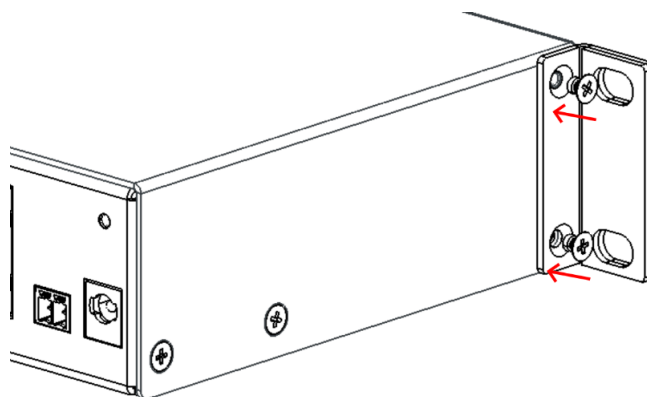

Figure 16: Short fixing bracket assembly



Figure 17: Front view rackmount of a device

3.1.2 Two-device rack mounting

The following parts shall be used for the joint rack mounting of two devices:

- B.** 2 × Side Binding Plate.
- C.** 2 × Short fixing bracket.
- D.** 1 × Rear Junction Plate.
- E.** 2 × M3 pan head screw.
- F.** 8 × M3 countersunk screw.

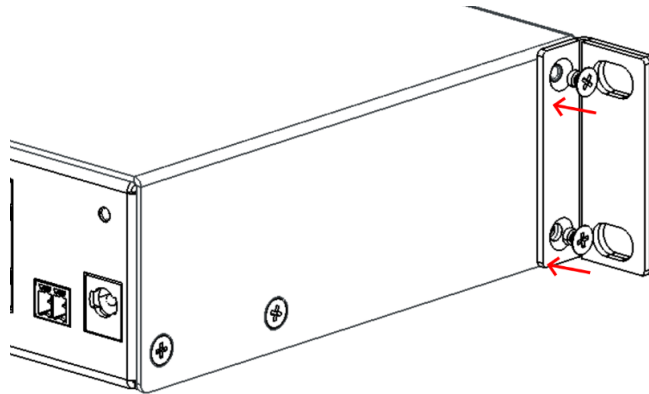

Figure 18: Short fixing bracket assembly

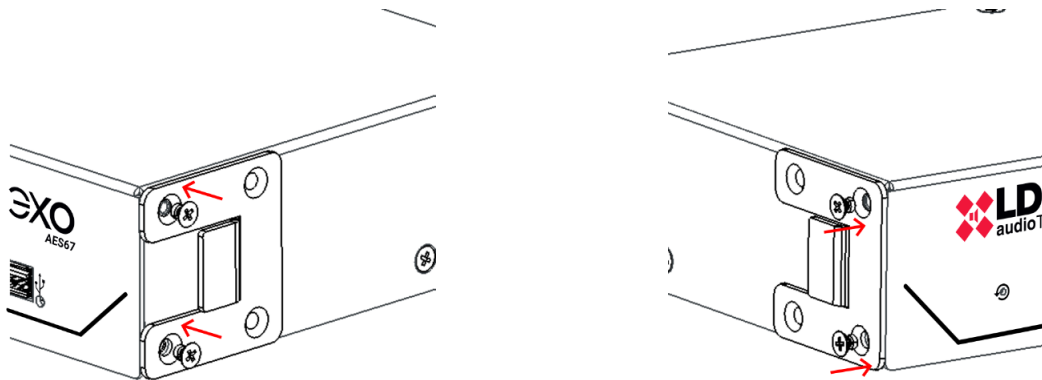

Figure 19: Side Junction Plate Mounting

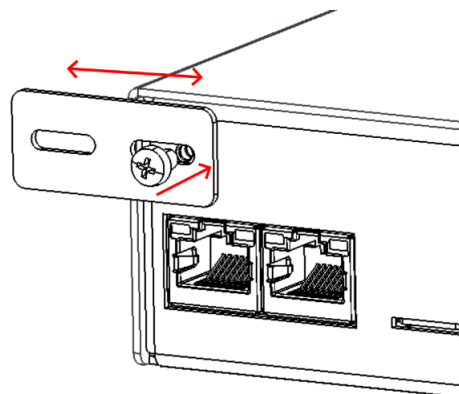

Figure 20: Rear Attachment Plate Mounting

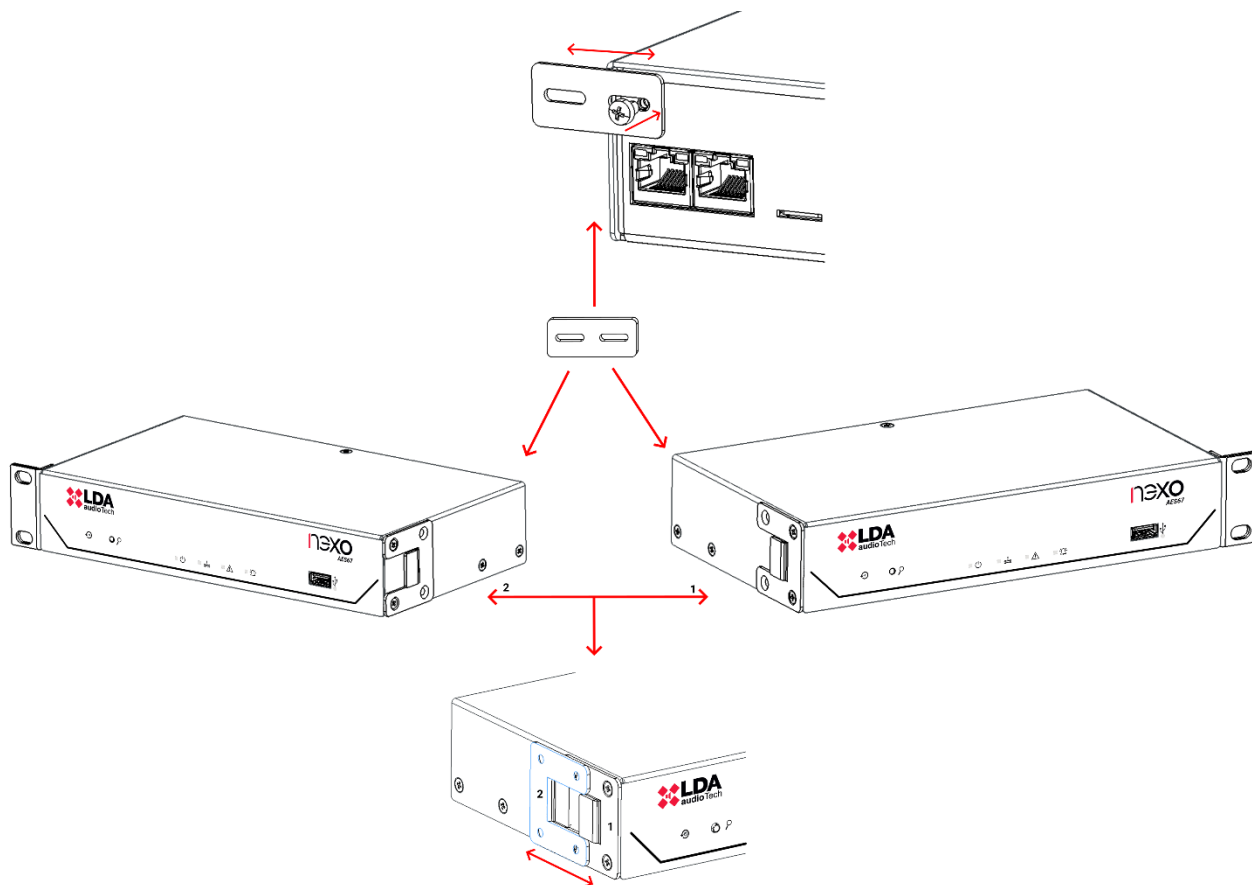

Figure 21: Two-device rackmount scheme

3.1.3 Wall Mounting

- C. 2 × Short fixing bracket.
- F. 4 × M3 countersunk screw.

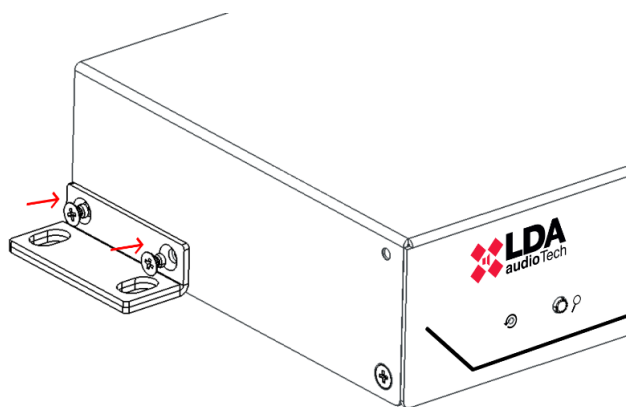

Figure 22: Short fixing bracket assembly

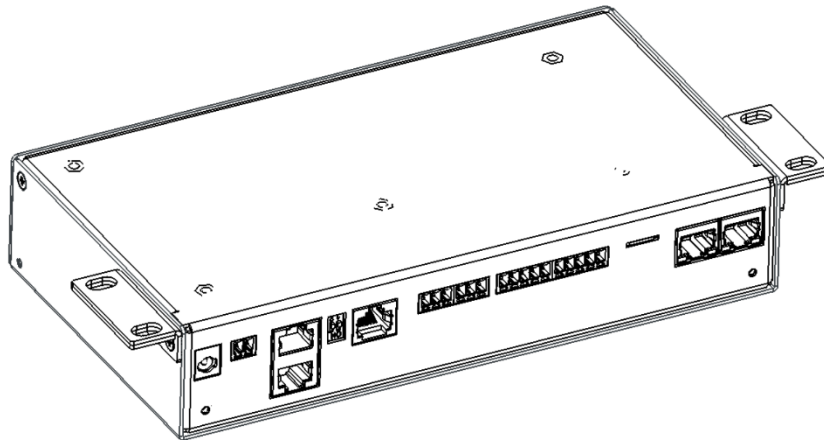



Figure 23: Wall Mount View

3.2 Power management

To ensure safe and continuous operation of the equipment, it is important to follow these steps during the power connection of the NEXO device:

- **Main power:** Connect the external 24V DC / 0.5A adapter to the round connector (DC jack) of the equipment, ensuring the correct polarity.
- **Emergency power:** Connect the EN54-4 certified battery system to the emergency port using the 2-pin Euroblock connector.
- **Power over Ethernet (PoE):** If powering the equipment over PoE, connect a compatible Ethernet cable (FTP CAT6A or higher) to port A RJ-45 and a PoE switch or injector that complies with the IEEE 802.3af Class 0 standard.

Before turning on the device, make sure that all connections are firm, properly polarized. Turn on the equipment and verify that the indicator  lights up green, indicating that the power has been done correctly.

3.3 Connections with NEO+ System

The NEXO device can be integrated into the NEO+ system through different network configurations, adapting to the specific needs of each installation. There are two main connection modes: Flexnet Ring Integration and Multi-Service Network Connection.

3.3.1 Flexnet Ring Integration

Flexnet is a communications standard, created by LDA AudioTech, that is used in NEO+ systems to segment their control and audio traffic across different VLANs, as well as providing a redundant ring-mode connection to the main controller.

To integrate NEXO within a Flexnet ring, it is necessary to enable Flexnet mode (VLANs) in the network configuration (see section 5.2.2 Network). according to NEO+ system parameters. Next, it is imperative to define the Flexnet Control VLAN and Flexnet Audio VLAN values, ensuring that they match those set in the system controller to ensure effective communication.

The physical connection must be made using both NEXO Ethernet ports to establish a redundant connection to the NEO+ system within the Flexnet ring. Connect the ports following the layout indicated in the following illustration.

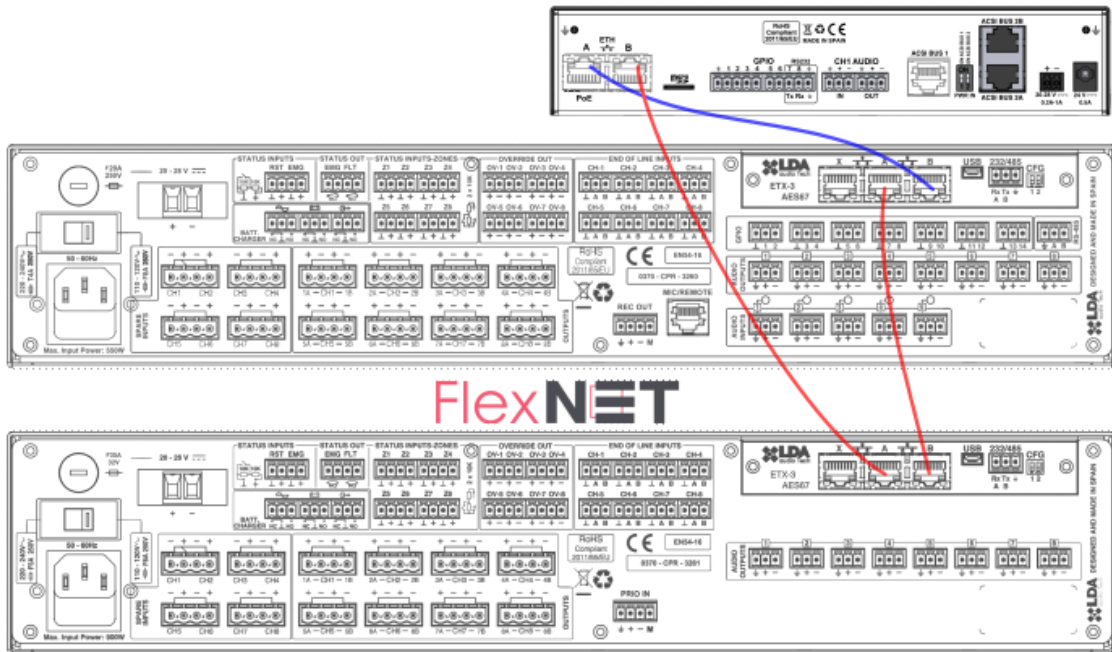

Figure 24: Flexnet Ring Integration with NEO+

For more information on the Flexnet protocol, please consult the NEO+ user manual available on the LDA Audio Tech Support website. You can access it through the following link: [Support - LDA Audio Tech](#).

3.3.2 Multi-service network connection

In installations where NEXO connects outside the Flexnet ring, either directly or through a shared multi-service network, only one of its Ethernet ports must be used, making the connection to the NEO+ system as shown in Figure 23.

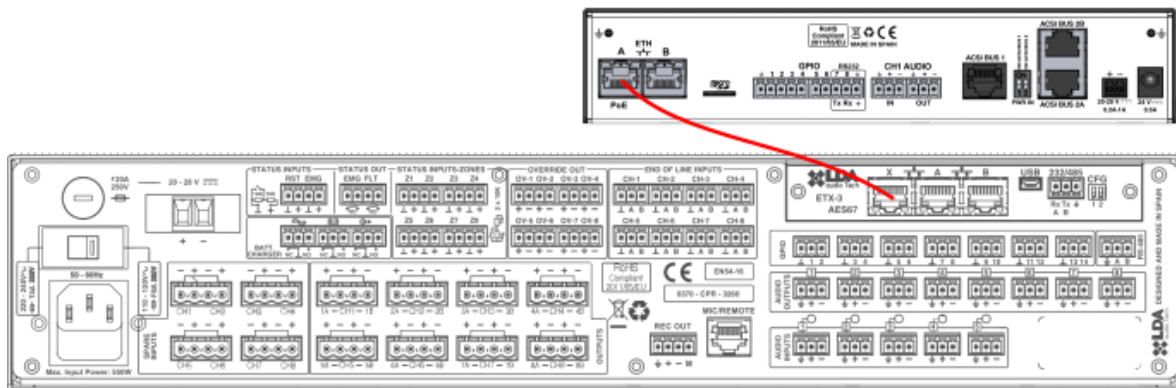

Figure 25: Multi-service network connection with NEO+

This mode allows NEXO to be integrated into a network infrastructure shared with other services. In this case, the configuration of VLANs is not mandatory, as the network can handle traffic in a conventional way. However, if the network requires VLAN segmentation, this function can be enabled in NEXO (see section 5.2.2 Network). In this NEXO connection mode outside the Flexnet ring, **it is imperative that both VLANs (control and audio) have the same identifier.**

NOTE: Network settings should be reviewed with your network administrator to avoid compatibility issues with other existing services on the network.

3.4 Connection with ONE Systems

The NEXO Hub device can be integrated with ONE system using the ACSiv1 protocol, acting as a gateway between the ACSINet Cluster and the ACSiv1 Site associated with the ONE system.

The physical connection is made through the ACSI BUS 1 port of the NEXO Hub and the ACSI port of the ONE system. In this configuration, ONE identifies the NEXO Hub as if it were two ACSiv1 microphones connected to its local bus. NEXO Hub generates a virtual MPS8Z microphone and a virtual VAP1 that allow the paging requests and actions received from the Cluster to be routed to the ACSiv1 bus.

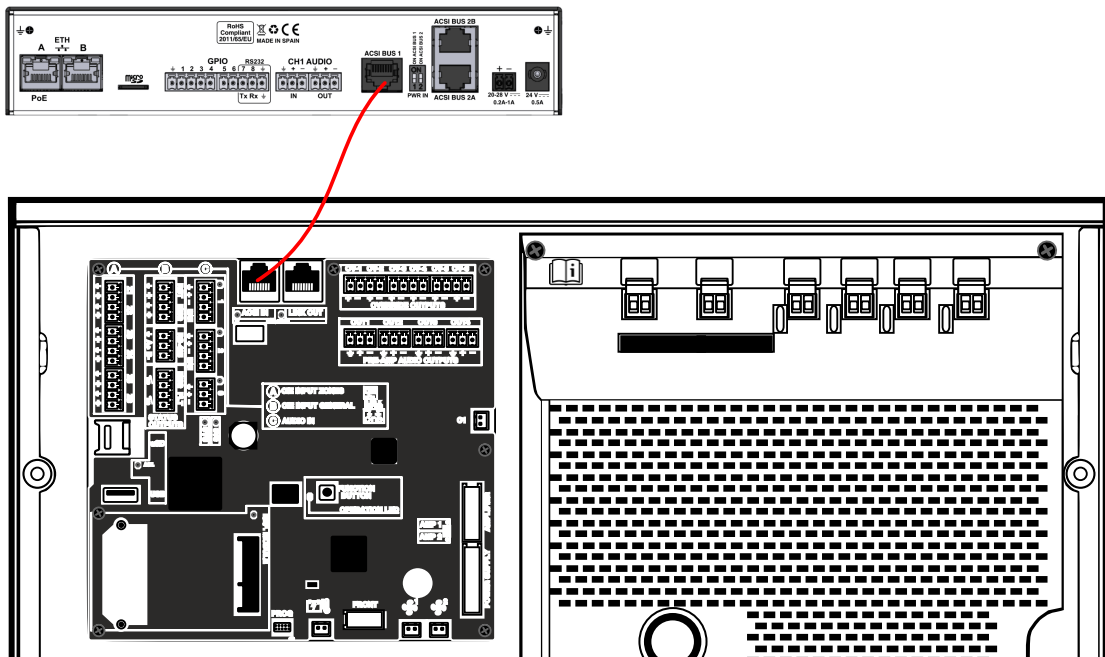

Figure 26. Connection with ONE system

NOTE: Some ACSiv2 functions are not compatible with the ONE system and its implementation is based on the ACSiv1 protocol. The use of VAP1FES devices, custom assignment of buttons to zones or groups, and the launching of triggers or events are not allowed.

4 ACSINET SYSTEM

ACSINet is a technology developed by LDA Audio Tech with the objective of expanding public address and evacuation system connectivity beyond the physical limitations of the traditional ACSS bus. Its main purpose is to enable the connection of ACSIV2 devices (such as microphones and control panels) over Ethernet networks, making it ideal for distributed installations and multi-service environments.

ACSINet allows both audio and control data to be transported via multicast communications, ensuring synchronized operation between system devices.

Thanks to this technology, it is possible to create advanced structures such as ACSINet Domains, made up of devices within the same installation, and ACSINet Clusters, which allow multi-service connections through NEXO Hub devices.

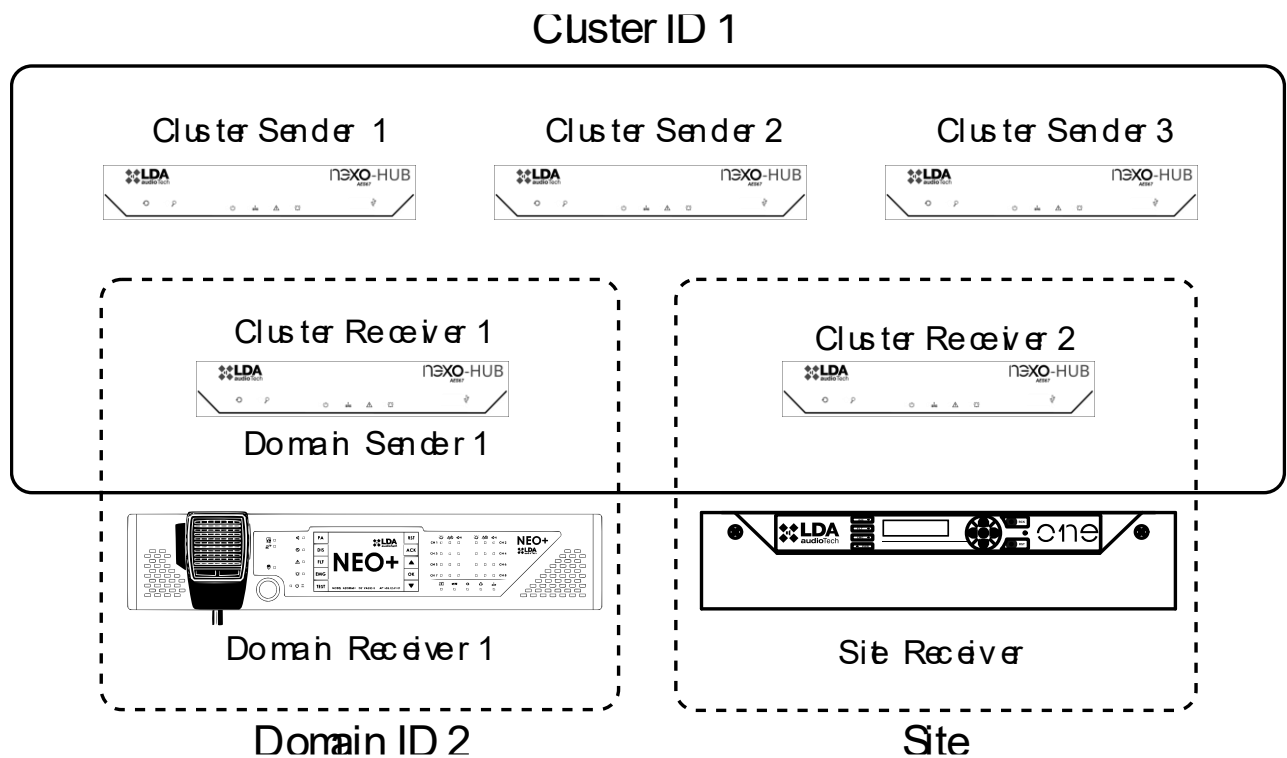

Figure 27: ACSINet System

NOTE: The ACSINet protocol is directly compatible with ACSIV2 devices. Integration with ACSIV1 based systems is limited to specific configurations with NEXO Hub, where the device acts as a gateway between the ACSINet Cluster and an ACSIV1 Site associated with ONE system.

4.1 ACSINet Domain

An ACSINet Domain logically groups NEXO devices with a NEO+ system, thus extending the performance and connectivity capabilities of the system.

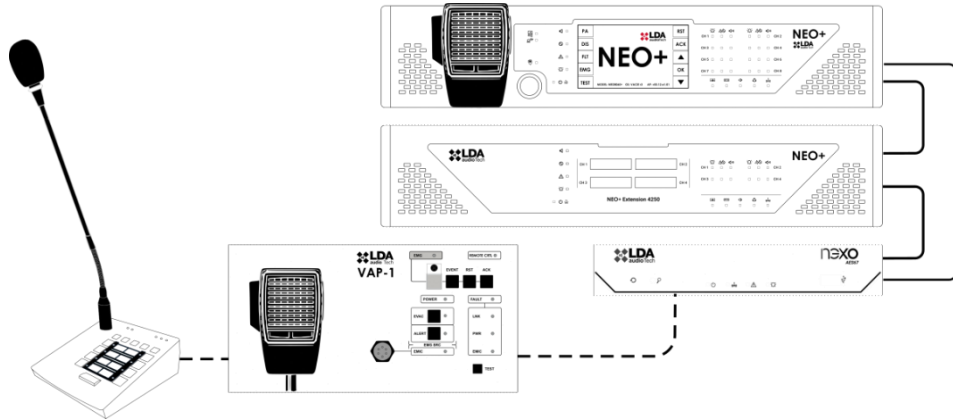

Figure 28: ACSINET Domain

Devices belonging to the same ACSINet Domain share the same Domain ID configuration. This parameter is the one that defines the set of multicast addresses that the different members of the domain will use for their communications both at control and AES67 audio level over the network. See Appendix II Network Specifications.

Each Domain must include at least one NEO+, which acts as a receiver and link to the system, as well as a number of NEXO devices that extend the functionality of the system, such as expanding the number of ACSI v2 devices that can be connected with greater flexibility. Within an ACSINet Domain, two device roles are defined:

- **Domain Receiver:** This role belongs to the NEO+ controller within an ACSINet Domain. Its main function is to link the system with the set of Senders of the Domain, distributing the current status information to all members of the Domain. In addition, it will be in charge of receiving and managing the requests from the Senders (e.g., the granting of speech to the different microphones connected via ACSINet).
- **Domain Sender:** It corresponds to the NEXO devices that are part of an ACSINet Domain. Its main function is to extend the system's performance, acting as nodes for remote connection of other elements to the system, such as microphones and control panels. Up to **128 Senders** can be installed within an ACSINet domain, which must be configured with a different Sender ID.

For complete configuration details of Domain ACSINet, see chapter 5.5.1 ACSINet Domain Config.

4.2 ACSINet Cluster

An ACSINet Cluster is a logical grouping of NEXO Hub devices to create a distributed system architecture following a multi-site topology.

NEXO Hub is a NEXO device with advanced functions, such as the ACSINet Cluster, which has been enabled by installing a specific license (in uSD card format). See chapter 2.2.2 MicroSD socket.

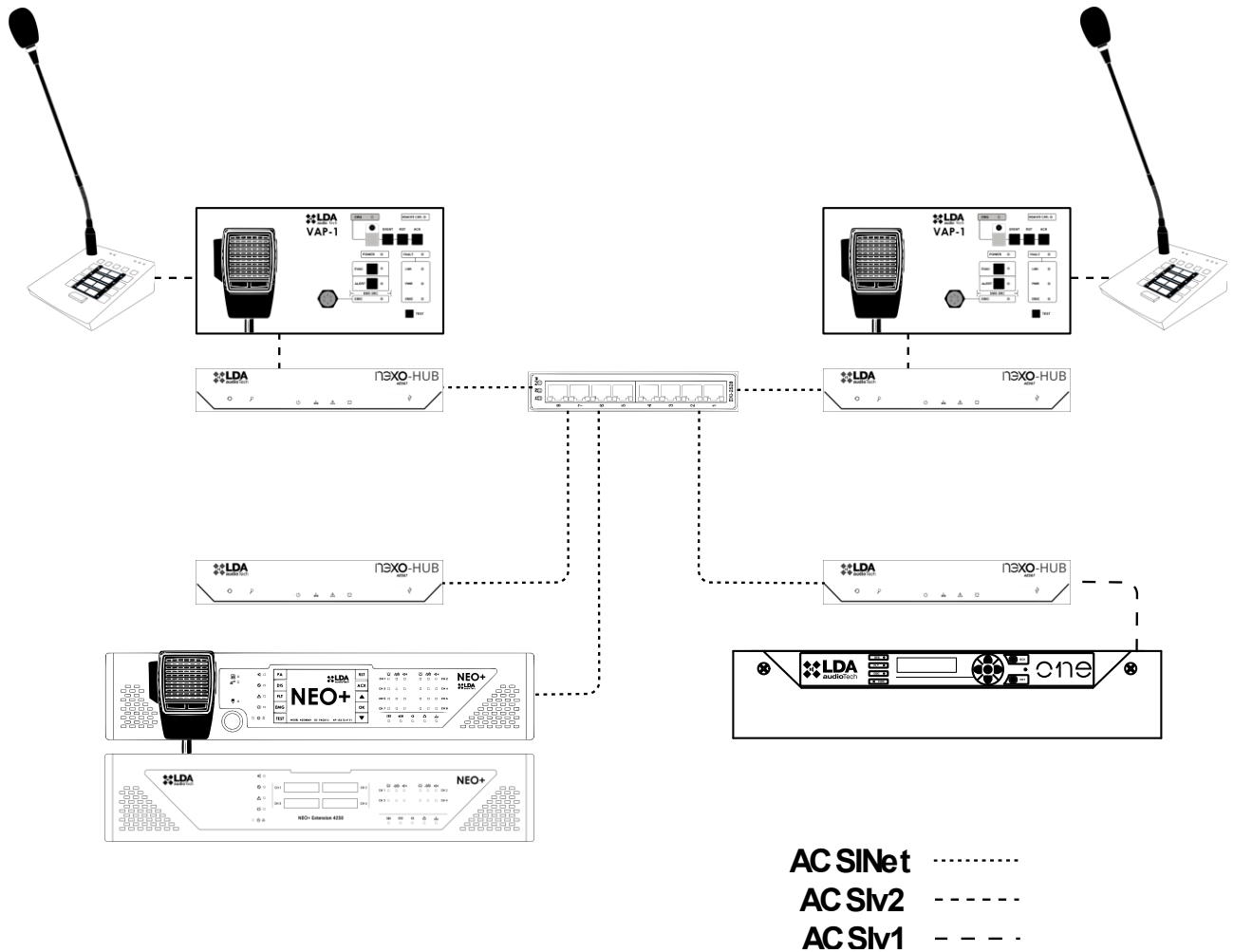

Figure 29: ACSINet Cluster

Within the ACSINet Cluster, two different roles can be differentiated:

4.2.1 Cluster Sender

NEXO Hub device designed to extend the system by creating a new higher hierarchical level, giving it multi-site control capability. It does this by integrating new devices, such as microphones or remote ACSiv2 control panels, whose requests will be routed to different locations or sites through each of the Cluster Receivers that act as a gateway to its Domain.

4.2.2 Cluster Receivers

The function of the Cluster Receiver is to act as a gateway to the PA/VA system by transmitting the orders and paging requests that are generated in the Cluster from a higher level, ensuring that remote calls reach the local systems.

NOTE: It is important to note that Cluster Receivers cannot have ACSi microphones connected to their local bus.

(a) Gateway to ACSINet Domain

In ACSINet Domain systems, the NEXO Hub fulfils a dual role, since in addition to being a Cluster Receiver, it is also a Domain Sender towards the PA/VA system, typically a NEO+ system.

At the level of information flow between Cluster and Domain, the following classification can be made:

From the Cluster to a Domain:

- Paging requests from the ACSI microphones connected to the Cluster Senders are transmitted.
- Local errors of the NEXO Hubs that form the Cluster are notified.
- Faults in the supervised ACSI links are reported.
- If the Cluster Receiver is supervised, the NEO+ Receiver of the Domain will detect and notify these faults as system errors.

From each Domain to a Cluster:

- The general status indicators of the NEO+ system of that site are distributed: (EMG, FLT and DIS).
- The link status between the NEXO Hub Receiver and the NEO+ system is supervised.
- No specific information about zones or groups is transmitted.

(b) Gateway to ACSiv1 Site

In gateway mode to an ACSiv1 Site, the NEXO Hub Receiver acts as a link between the ACSINet Cluster and a ONE system based on ACSiv1. In this configuration, the ONE system identifies the NEXO Hub Receiver as two ACSiv1 microphone devices: an MPS8Z for general PA paging calls and a VAP1 for VA emergency calls and actions.

At the level of information flow between Cluster and ACSiv1 Site, the following classification can be made:

From the Cluster to an ACSiv1 Site:

- Paging requests from the ACSI microphones connected to the Cluster Senders are transmitted.
- The available functions of an ACSiv1 microphone are transmitted, including the functions specific to a VAP1 for VA emergency calls.

From each ACSiv1 Site to the Cluster:

- The general status indicators of the ONE system associated with the Site are distributed: EMG and FLT.
- The link status between the NEXO Hub Receiver and the ONE system is supervised through the ACSiv1 bus.
- No specific information about zones or groups is transmitted.

NOTE: In gateway mode to ACSiv1 Site, the use of VAP1FES is not allowed. Its integration is designed for ACSiv2, so its operation is not suitable in systems based on ACSiv1.

4.3 Virtual Mic

The "Virtual Mic" function expands the connectivity of the system, adding the possibility of integrating conventional single-zone microphones and/or trigger launchers to the ACSINet ecosystem via NEXO.

The "Virtual Mic" mode has three different functions:

- **Contact closure microphone connection:** It allows up to 2 conventional analog audio microphones and contact closures to be connected to the system via ACSINet, using the CH1 and BUS ACSI audio inputs and the GPIO ports for TALK and BUSY functions.

In addition, thanks to the bus mode of the LDA-A1 microphones, it is possible to connect **up to 4 A1 microphones** via the CH1 input from a single NEXO.

- **Noise gate microphone connection:** Allows to activate the speech request of up to inputs per noise gate, when the audio level exceeds the configured activation threshold.

This function is supported by both conventional analog microphones and prerecorded message and announcement servers.

- **Trigger launch from contact closures:** The NEXO GPIO ports can be configured as inputs to act as triggers available in the configuration of events and actions in the NEO+ system.

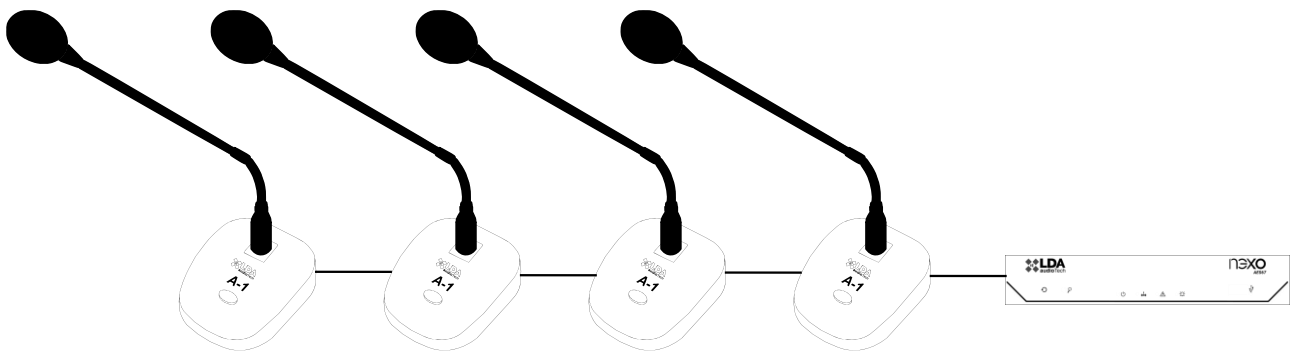

Figure 30: Example of Configuration, Virtual Mic - A1 Mic Bus

NOTE: GPIOs cannot be assigned to multiple functions. If a GPIO is already assigned as an A1 or generic microphone input, it cannot be used as a trigger, and vice versa.

To find out how to configure this functionality in detail, see the section 5.5.4Virtual Mic Mode.

5 CONFIGURATION. NEXO CONFIG TOOL APP

It is recommended that the personnel in charge of the configuration should have a solid knowledge of Layer 3 IP audio networks, including protocols such as AES67 and Dante.

NEXO Config Tool is the official tool that allows users to manage and configure the NEXO device. The following are the steps to install and access the app:

NOTE: The images and directions in this manual are described using the **NEXO Config Tool software version v1.2.0** and the NEXO firmware version **v01.02.00.00**.

Prerequisites: It is compatible with Windows 10 and 11 operating systems. It requires having the .NET 8.0 framework installed, which can be downloaded from Microsoft's official website if it is not previously installed.

Download: The application is available on the official website of LDA Audio Tech Support. You can access its download through the following link: [Support - LDA Audio Tech](#)

Installation: The application is distributed in a ZIP file. Extract its contents and run the NEXOConfigTool.exe file. No additional installation is necessary.

Access: After running the application, an access password window will appear. Please contact LDA's technical support team to obtain this password via email support@lda-audiotech.com.

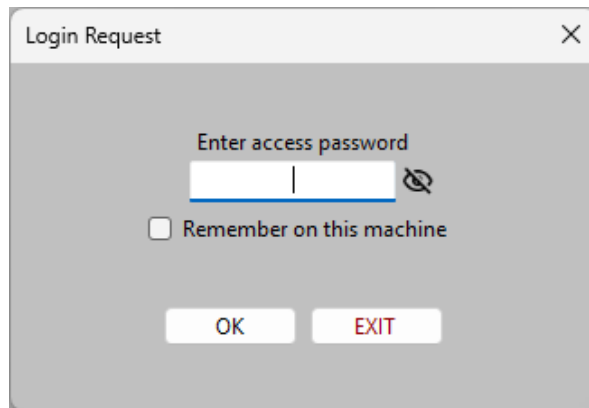

Figure 31: Login

5.1 Interface

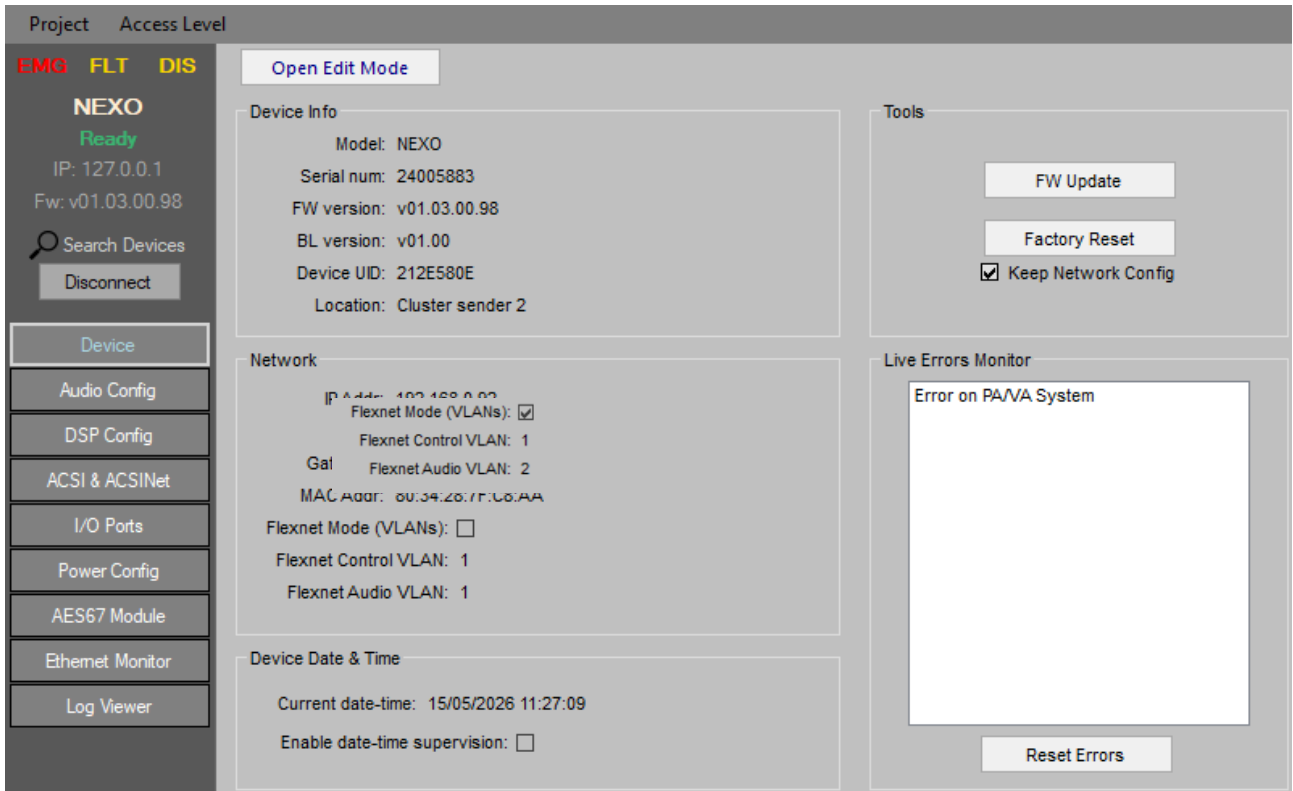

Figure 32: NEXO Config Tool Interface

5.1.1 Menu Bar

Located at the top of the window, the menu bar provides access to advanced project management options and system access settings. It contains the following menus:

- **Project:** Includes options such as restarting the device, importing/exporting settings from files, and closing the app.
- **Access Level:** Allows you to change the access level and manage user authentication.

5.1.2 Left Panel

This dashboard provides an overview of the system status and direct access to the various configuration sections.

System Status Indicators:

- **EMG (Emergency):** Displays the emergency status of the system.
- **FLT (Failure):** Indicates errors or failures detected in the system.
- **DIS (Disarmed):** Reflects the deactivation status of system zones.

Device connection status:

- **Not Connected:** No connection has been established with any device.

- **No link:** A connection has been established, but the device is not reachable.
- **Ready:** Connection established, no activity in progress.
- **Working:** The device is processing changes or receiving data.

Network and connection data:

- **NEXO IP address.**
- **Firmware** version installed on the device.
- **Search Devices:** Opens the LDA Discover Tool to search for LDA devices on the network.
- **Connect/Disconnect:** Allows you to establish or terminate the connection with NEXO.

Configuration sections:

- **Device:** General information about the device.
- **Audio Config:** Configuration of audio input and output channels.
- **DSP Config:** Volume and EQ management of audio input and output channels.
- **ACSI & ACSINet:** Management of the ACSINet Domain and Cluster and devices connected to the ACSI bus.
- **I/O Ports:** Configuration of GPIO ports and RS232 serial ports.
- **Power Config:** Configuration of the supervision of the device's local power inputs, as well as monitoring of the status of the external EN54-4 EPS charger through contact closures.
- **AES67 Module:** Real-time monitoring of audio transmission and reception using AES67 protocol.
- **Ethernet Monitor:** Monitoring of the Ethernet traffic received and transmitted by the network ports and by the internal communications processor.
- **Log Viewer:** View and export event logs.

5.1.3 Center Panel

The central panel is the area where the various system parameters are displayed and configured. Its content varies according to the option selected in the Left Panel, allowing you to modify the configuration of the device in a structured way. To make changes to the settings, it is necessary to activate the edit mode through the "Open Edit Mode" button, located at the top of each section.

5.2 Device

The "Device" window displays and allows you to configure basic parameters of the device. Some of these parameters are configurable. To access this setting press the "Open Edit Mode" button

5.2.1 Device info

Displays the general information of the device: model, serial number, firmware version, bootloader version, and unique identifier of the device within the system.

The "Location" field allows you to assign a custom label to identify the equipment physically in a location.

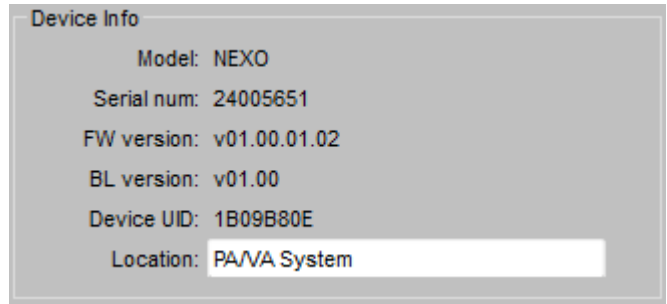

Figure 33: Device Info

5.2.2 Network

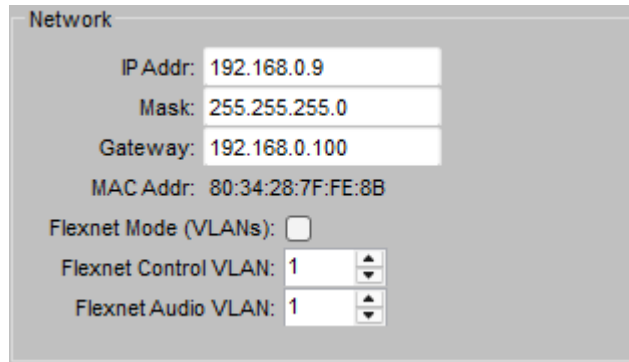

Figure 34: Network

Allows you to configure the network parameters of the device: IP address, subnet mask, and gateway.

- **Flexnet mode (VLANs):** Enables audio and data transmission using dedicated VLANs. To integrate the equipment within the Flexnet ring, this option must be enabled and configured with the same VLAN values as the system controller.

By default, Flexnet mode is disabled, which means that network traffic is managed without VLAN segmentation.

- **Flexnet Control VLAN:** Identifier for the data VLAN of the Flexnet protocol. By default, it will have a value of 1. Supports values from 1 to 4095.
- **Flexnet Audio VLAN:** Identifier for the AES67 audio VLAN of the Flexnet protocol. By default, it will have value 1. Supports values from 1 to 4095.

NOTE: A VLAN value equal to 0 disables segmentation.

5.2.3 Device Date & Time

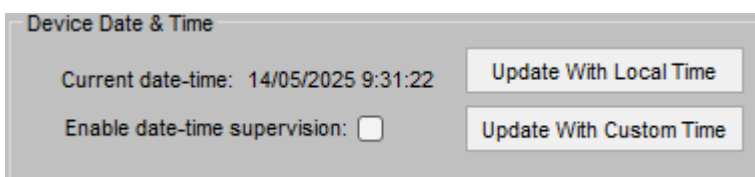

Figure 35: Device Date & Time

Displays the current date and time of the device.

With the "Update" button it is possible to synchronize the time of the device with the local time of the equipment through which we establish a connection with NEXO.

The "Update With Custom Time" button opens a date and time selection window allowing to set the date and time in a custom way on the device. Click "Confirm Changes" to apply the settings.

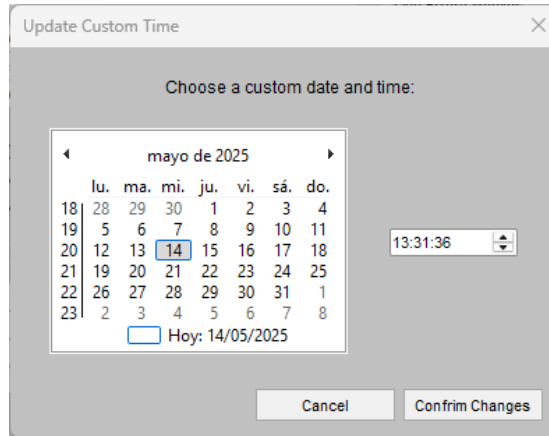

Figure 36: Update Custom Time

Selecting the check "Enable date-time supervision" will enable the supervision of the internal pile of the device and will notify if the time is lost due to discharge of the pile. By default, monitoring is disabled.

5.2.4 Tools

The "FW update" button allows you to upload a firmware file to update the device. You can download the latest version available on the LDA Audio Tech Support website, through the following link [Support - LDA Audio Tech](#).

The "Factory Reset" function restores the device to factory defaults. To keep the network parameters configured in the Network section, select the "Keep Network Config" option.

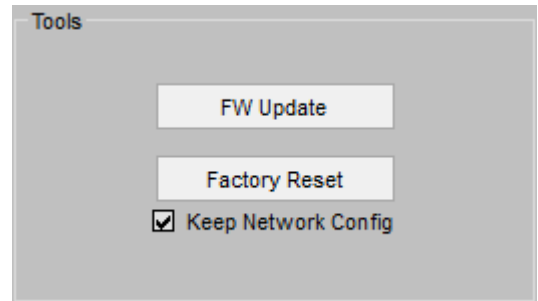

Figure 37: Tools

5.2.5 Live Errors Monitor

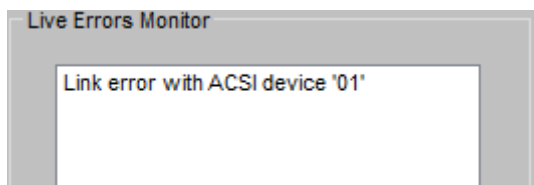

Figure 38: Live Error Monitor

This section shows real-time errors related to the operation of the equipment.

The "Reset Errors" button allows the active local errors of the device to be cleared. This button only clears NEXO's own faults, not the active faults of the associated system.

NEXO local errors will also be cleared when a global fault reset is performed from the PA/VA system controller. If the error persists, the associated record will appear again.

To view the historical record of errors detected by the device see chapter 5.10 Log Viewer.

5.3 Audio Config

In the "Audio Config" tab, you manage the transmission and reception of NEXO audio. The configuration matrix allows for custom assignment of input and output channels either via the AES67 protocol, the ACSINet protocol, or via physical channels.



Figure 39: Audio Config

Each input and output have a vumeter that displays the audio level in dB in real time.

5.3.1 Inputs

The "Inputs" section in the "Audio Config" tab allows you to configure different audio sources according to the selected input channel.

(a) Input 1: CH1 Analog Audio In

Receive analog audio through physical input.

- **Volume (dB):** Adjusts the value of the input volume, with values between -100 and 10 dB.
- **Mute:** Mute the audio input.
- **EQ Enabled:** Enables the channel equalization filters. Its configurable parameters are detailed in section 5.4 DSP Config.
- **Phantom power:** Activates the 24VDC phantom power supply to the input.

This input may be controlled by the ACSINet protocol when the "Virtual Mic" function is active. For more information, refer to the chapters 5.3.3 ACSINet-controlled channels and 5.5.4 Virtual Mic Mode.

(b) Input 2: ACSI Bus Analog Audio In

Input for microphones compatible with the ACSI Bus as well as MPS8Z, MPS8Z+, VAP-1 and VAP-FES.

Up to 32 ACSI devices can be connected to the same NEXO, depending on the characteristics of each microphone, to be integrated into the same ACSINet domain

- **Volume (dB):** Adjusts the value of the input volume, with values between -100 and 10 dB.
- **Mute:** Mute the audio input.
- **EQ Enabled:** Enables the channel equalization filters. Its configurable parameters are detailed in section 5.4 DSP Config.

This input can be controlled by the ACSINet protocol when the device is integrated within an ACSINet Domain. For more information, see chapters 5.3.3 ACSINet-controlled channels and 5.5.1 ACSINet Domain Config.

(c) Inputs 3 & 4: AES67 Rx Slots

These inputs receive audio streams using AES67 protocol

- **Rx Enabled:** Enables audio reception using the AES67 protocol on the input channel.
- **Stream ID (bundle):** Defines the audio receive stream. Set values between 1 and 255. Each Stream ID corresponds to a defined multicast IP address.
- **Channel:** Specifies the channel within the audio stream. Set values between 1 and 8.
- **IP Address:** Editable only in "Advanced" mode. Allows you to define the multicast IP address for audio reception. If you set an invalid IP address, the Stream ID will be disabled (value 0).
- **Port:** Editable only in "Advanced" mode. Indicates the port of reception. By default, AES67 uses port 5004.

Input 3 can be controlled by the ACSINet protocol when zone monitoring is activated. For more information, see the chapters 5.5.1 ACSINet Domain Config and 5.3.3 ACSINet-controlled channels.

5.3.2 Outputs

In the "Audio Config" tab, the "Outputs", allow you to assign the audio channels configured on the inputs to their respective destinations.

By default, outputs will not have any input source assigned.

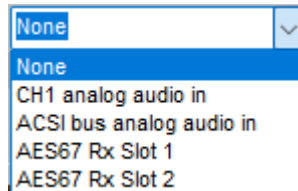

Figure 40: Input channels

(d) Output 1: CH1 Analog Audio Out and Output 2: ACSI Bus Analog Audio Out

It allows analog audio to be transmitted to a connected physical device.

- **Select Input:** Assigns the input channel that will feed this output (CH1, ACSI, AES67).
- **Volume (dB):** Adjusts the audio level between -100 and 0 dB.
- **Mute: Mute** the audio output.
- **EQ Enabled:** Enables the channel equalization filters. Its configurable parameters are detailed in section 5.4 DSP Config.

Output 1 corresponds to the CH1 analog output of the device. It may be controlled by the ACSINet protocol when zone monitoring is activated. For more information, refer to chapters 5.5.5 Zone Monitor Config and 5.3.3 ACSINet-controlled channels.

Output 2 corresponds to the analog audio output through the ACSI bus. The physical port used will depend on the ACSI bus topology selected in the device configuration. For more information about the use of the ACSI ports, refer to section 2.2.4(d) BUS ACSI.

(e) Outputs 3 & 4: AES67 Tx Slots

These outputs transmit audio using the AES67 protocol to configure multicast addresses.

- **Tx Enabled:** Enables audio streaming on the output channel. When an input source is selected, the transmission is automatically activated.
- **Stream ID (bundle):** Configures the Audio Stream Stream.
- **Channel:** Specifies the channel of the stream to be broadcast.
- **IP Address:** Editable in "Advanced" mode, defines the multicast IP address for the stream.
- **Port:** Defines the transmit port (default, 5004).
- **Stream Name:** A descriptive label for the audio stream.
- **SAP Announcement:** Editable only in "Advanced" mode. Allows third-party devices to identify the stream.

- **Audio Encryption:** Editable only in "Advanced" mode. Blocks audio reception to non-LDA devices.

Output 4 can be controlled by the ACSINet protocol when the equipment is integrated within an ACSINet domain. For more information, see the chapters 5.5.1 ACSINet Domain Configuration and 5.3.3 ACSINet-controlled channels.

5.3.3 ACSINet-controlled channels

The message "**Controlled by ACSINet**" may appear on some inputs and outputs, when the specifications mentioned above in each section are met.

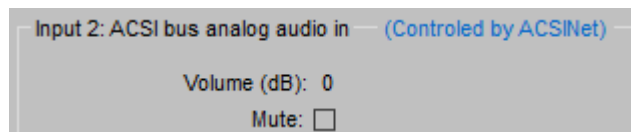

Figure 41: Controlled by ACSINet

This indicator indicates that the channel is being managed directly by the ACSINet protocol, which means that any manual configuration made on these inputs or outputs will have no effect.

When a channel is controlled by ACSINet, the audio input or output settings are automatically defined based on the ACSINet domain to which NEXO is linked. Values such as volume level, mute, or stream assignment in AES67 are disabled for manual editing. In the case of audio outputs, the channel can only be used for the assigned function within the ACSINet system, such as zone monitoring using the zone monitor.

This behavior affects various configurations within Audio Config, including:

- Input 1: CH1 analog audio in (when the Virtual Mic function is active)
- Input 2: ACSI Bus Analog Audio In (when the device is integrated into an ACSINet domain)
- Input 3: AES67 Rx Slot 1 (when zone monitoring is enabled)
- Output 1: CH1 Analog Audio Out (when zone monitoring is enabled)
- Output 4: AES67 Tx Slot 2 (when the device is integrated into an ACSINet domain)

5.4 DSP Config

The “DSP Config” tab allows to configure in real time the digital signal processing (DSP) blocks of the NEXO device. This window has been designed with a visual and modular approach, representing the internal structure of the audio stream.

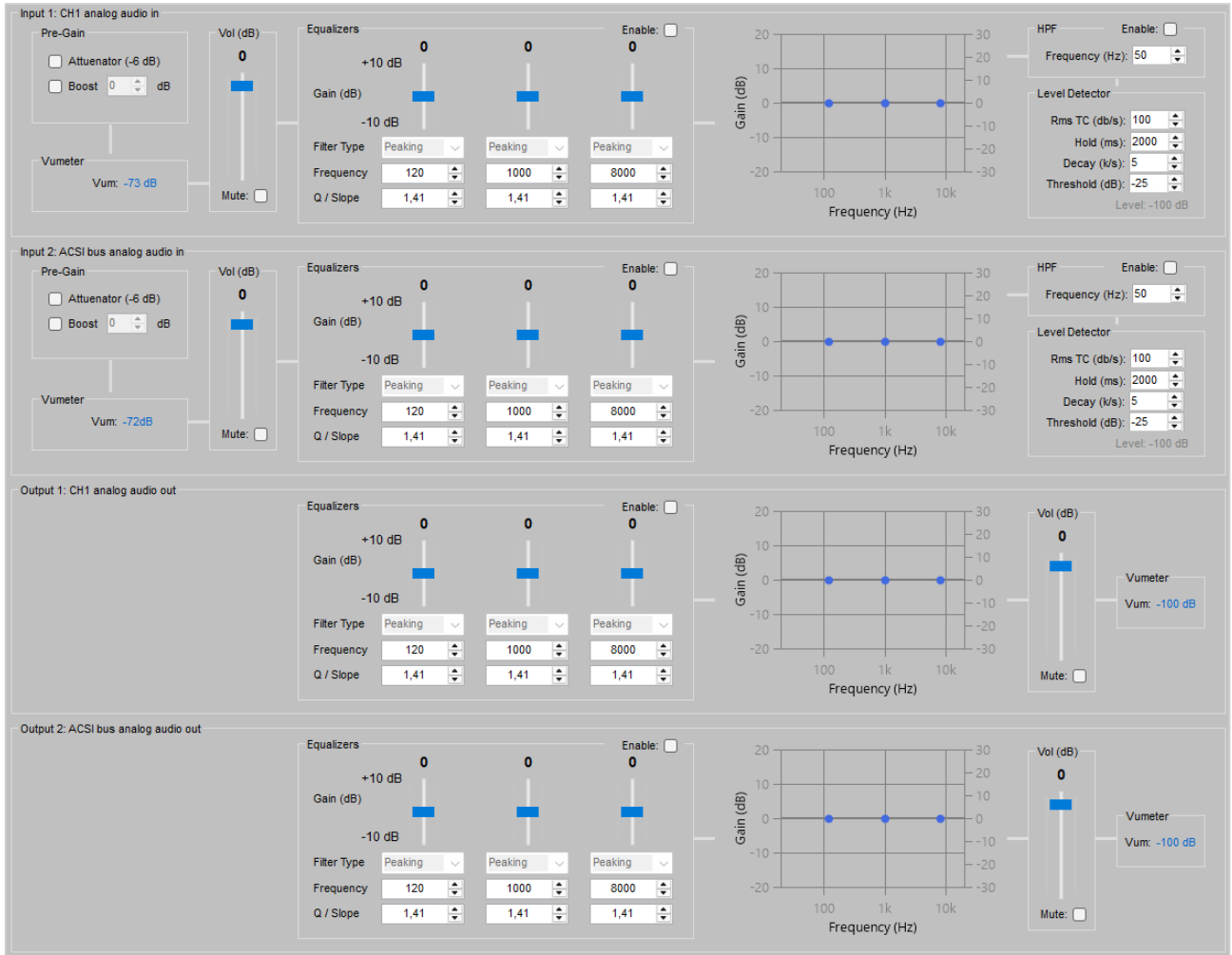

Figure 42: DSP Config

- **Pre-gain:** It allows to modify the input signal level, thus optimizing the signal-to-noise ratio and avoiding distortion when working with different input signal levels.
 - **Attenuator (-6dB):** Reduces the input signal level. Its value is set at -6dB.
 - **Boost:** Increases the input signal level. Its values are adjustable from 0 to 24dB.
- **Vumeter:** Not configurable. Displays a real-time audio level reading of the signal.
- **Vol (dB):** It allows to adjust the signal level of the input or output channel, as well as to activate or deactivate the mute function.
- **Equalizers:** Includes parametric filters for each channel. To apply the configuration, click on the “Enable” checkbox located on the right side of the window. The configurable values are:
 - **Gain:** With a range of ±10dB.
 - **Filter Type:** Currently limited to Peaking.

- **Frecuency:** It determines the central frequency on which each equalizer acts, applying the defined gain. Values from 50Hz to 20kHz.
- **Q/Slope:** Controls the filter bandwidth.

When each filter is active, check “Enable” to the right of the window, its curve is graphically represented in the right area. If an equalizer is disabled, the corresponding curve is displayed in gray to indicate that no equalization is being applied at that point.

- **HPF (High Pass Filter):** Allows to eliminate low frequencies by means of a high pass filter according to the set cutoff frequency. It must be enabled by checking “Enable” on the right side of the box.

Level Detector: Noise gate values for voice detection and request management of the “Virtual Mic Mode” utility, see 5.5.4 Virtual Mic Mode.

- Virtual Mic Mode.
 - **RMS TC (dB/s):** Level integration time.
 - **Hold (ms):** Retention time of the level after detection.
 - **Decay (dB/s):** rate of level drop.
 - **Threshold (dB):** Threshold for activating the detector.

Changes made in this window are applied in real time but are not automatically saved to the device's memory. In case the device is restarted with the settings not saved, the settings will be lost and the previously configured or default values will be restored.

To keep the changes permanently in the unit's configuration, click “**Save to Config**”.

If you wish to discard the changes made and recover the previously saved configuration, click on “**Discard Runtime Changes**”.

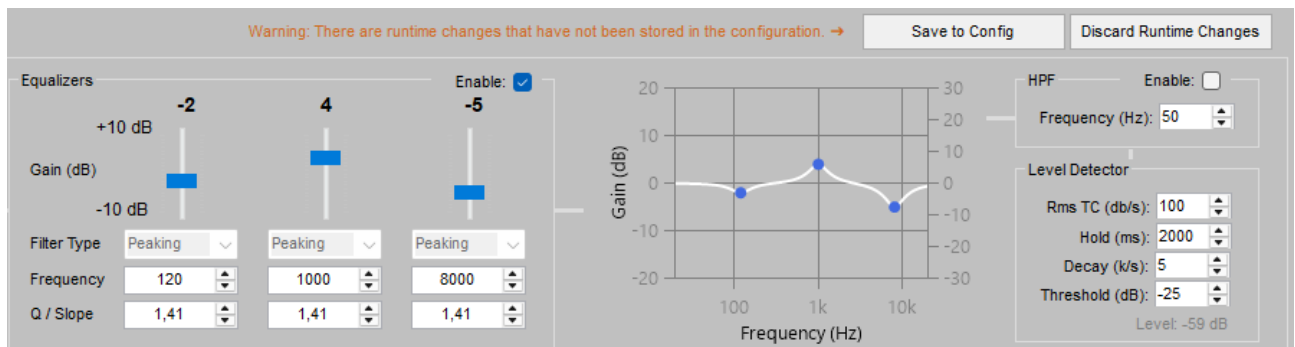

Figure 43: Save to Config

NOTE: The **runtime** configuration warning will also be notified in the 5.3 Audio Config window. Until the DSP configuration is **saved** or **discarded**, it will not be possible to access the edit mode.

5.5 ACSI & ACSINet

The "ACSI & ACSINet" tab allows you to manage the configuration of the ACSINet Domain and the devices that compose it.

5.5.1 ACSINet Domain Config

The "ACSINet Domain Configuration" section allows you to configure the parameters required for the integration of NEXO into an ACSINet domain.

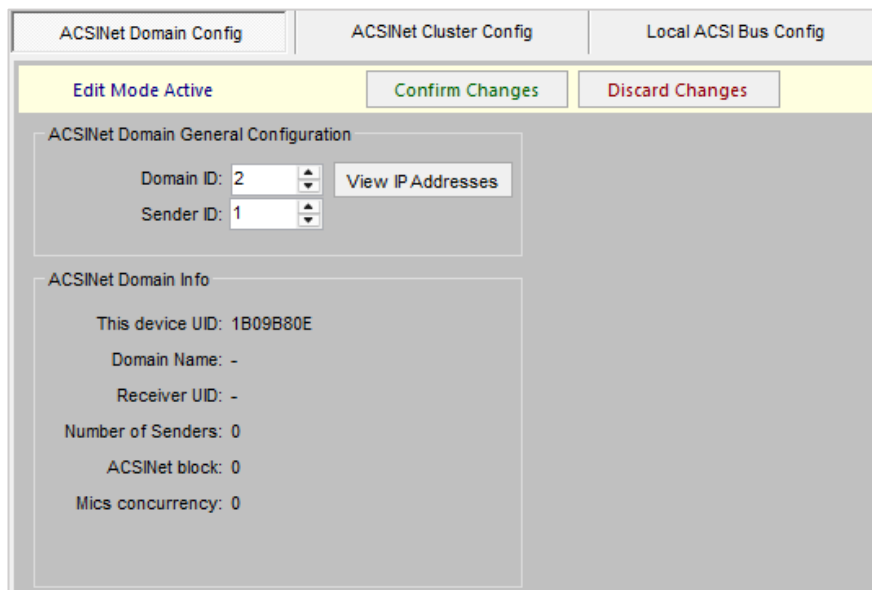

Figure 44: ACSINet domain

(a) ACSINet Domain Configuration

This section allows you to modify the configuration of the domain where NEXO is integrated:

- **Domain ID:** Domain identifier, with a value between 1 and 128. It must match the value configured in the system controller where it is integrated.

NOTE: Cluster and Domain share the same multicast addressing space. Therefore, their configuration IDs must be different to avoid network overlaps. Matching these IDs causes multicast addressing conflicts and critical communication errors.

- **Sender ID:** Identifies the device as the sender within the ACSINet domain. Each NEXO within the same domain must have a unique value between 1 and 128. For a domain to be active, at least one issuing device must exist, otherwise the domain will remain disabled.

(b) ACSINet Domain Info

At the bottom, the current status of the domain is displayed, providing information about the domain configuration:

- **This device UID:** Unique identifier of the device within the ACSINet Domain.

- **Domain Name:** Identification label of the ACSINet Domain. This name appears on all devices configured in the same domain.
- **Receiver UID:** Unique identifier of the NEO+ receiver, within the domain.
- **Sender number:** The total number of active sender devices within the domain.
- **ACSINet block:** Its value matches the Domain UID.
- **Mics concurrency:** Maximum number of emitters that can simultaneously stream audio in the domain, maximum 16.

NOTE: Do not confuse the **concurrency** of the **ACSINet Domain**, with the number of devices that can send audio over the **ACSI Bus**, which is limited to 1.

5.5.2 ACSINet Cluster Config

ACSINet Cluster mode allows expanding a distributed NEO+ system across multiple physical locations, integrating licensed NEXO HUB devices as interconnection points between independent domains. This architecture allows microphones and events to be shared between different Domains in a controlled mode, maintaining the independence of the Domains and improving the scalability of the system.

Each NEXO HUB unit within the Cluster can play the role of Cluster Sender (central control station) or Cluster Receiver (gateway between Cluster and Domain). The role must be defined in the local configuration section and cannot be dynamically interchanged.

(a) ACSINet Cluster General Configuration

This section allows configuring the general parameters of the Cluster:

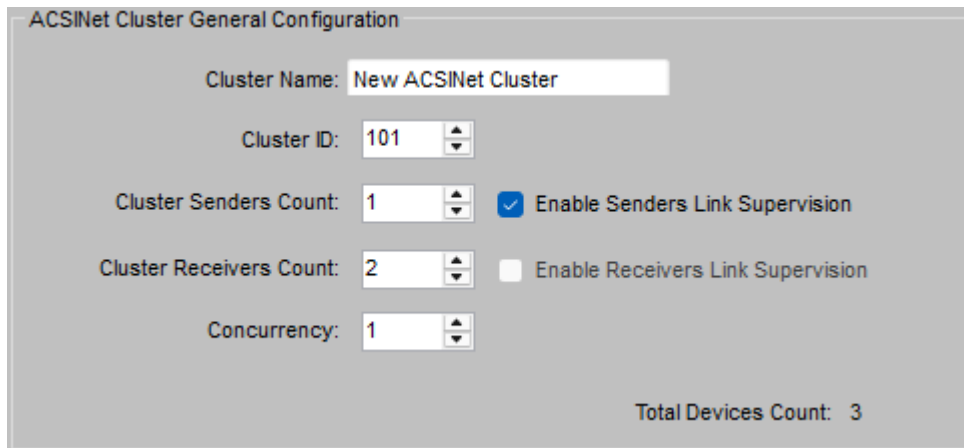

Figure 45: ACSINet Cluster Configuration

- **Cluster Name:** Descriptive label for Cluster identification, up to 32 characters. Appears on all NEXO Hub integrated into the same associated Cluster.
- **Cluster ID:** Cluster identifier, its value can be between 1 and 128.

NOTE: Cluster and Domain share the same multicast addressing space. Therefore, their configuration IDs must be different to avoid network overlaps. Matching these IDs causes multicast addressing conflicts and critical communication errors.

- **Cluster Senders Count:** Total number of Senders in the Cluster, maximum 127. All NEXO Hub belonging to the Cluster must have the same number configured.
- **Cluster Receivers Count:** Total number of Receivers in the Cluster, maximum 127. All NEXO Hub belonging to the Cluster must have the same number configured.
- **Concurrency:** Maximum number of Cluster microphones that can speak simultaneously, maximum 16. Once this limit is exceeded, all new speech requests will receive BUSY, regardless of priority.

NOTE: Once the concurrence is exceeded, a VA microphone can eject a PA microphone, occupying the last available channel.

- **Enable Senders/Receivers Link Supervision:** Optionally, inter-role link supervision (Sender/Receiver) can be enabled, which allows detecting communication failures between Cluster nodes.

(b) NEXO HUB Local Device Configuration

Defines the rol and the behavior of the NEXO Hub within the Cluster:

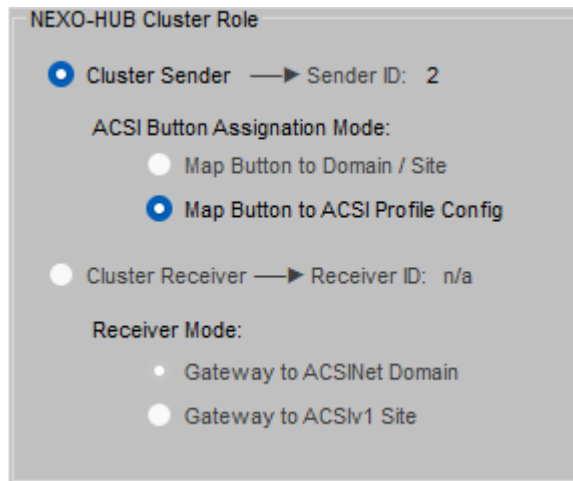

Figure 46: NEXO HUB Local Configuration

- **Cluster Sender:** Identifies the device as the sender within the Cluster. It is used in central control stations. Allows adding ACSlv2 microphones to the system physically located outside a Domain ACSINet. Each Sender will have a unique identifier with a value between 1 and 128.

A NEXO Hub configured as a Cluster Sender will not be able to belong to any ACSINet Domain.

ACSI Button Assignment Mode:

- **Map Button to Domain/Site:** Each ACSI button (corresponding to the physical zone buttons of the VAP1, VAP1FES, MPS8Z or MPS8Z+ devices) is directly associated with a system site, either an ACSINet Domain or an ACSlv1 Site, transmitting audio to all its zones. When a button is pressed, the request is directed to the associated **Domain or Site**.

NOTE: The use of the VAP1FES device at Cluster level is only possible in systems where there are no ACSlv1 sites.

- **Map Button to ACSI Profile Config:** With each ACSI profile configured in the controller of each Domain, the ACSI buttons are interpreted according to that configuration,

maintaining mapping independence for each Domain. In an ACSlv1 Site, since there is no profile configuration, each button points to the corresponding zone of the system.

- **Cluster Receiver:** Identifies the device as a receiver within the Cluster. It acts as a gateway between the local Domain and the Cluster. Each Receiver will have a unique identifier with a value between 1 and 128.

A NEXO Hub is configured as a Cluster Receiver, it will not allow ACSI microphones to be installed.

Receiver Mode:

- **Gateway to ACSINet Domain:** The NEXO Hub acts as a gateway between the Cluster and an ACSINet Domain associated with a NEO+ system. In this mode, the requests received from the Cluster are transmitted to the local NEO+ system.

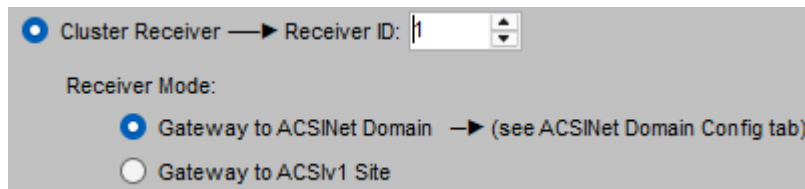

Figure 47: NEXO Hub Receiver to Domain

- **Gateway to ACSlv1 Site:** The NEXO Hub acts as a gateway between the Cluster and an ACSlv1 Site associated with a ONE system. In this mode, the requests received from the Cluster are adapted for integration with the local ONE system through ACSlv1. The ONE system automatically detects the NEXO Hub as two connected ACSI devices: an MPS8Z (for PA operations) and a VAP1 (for VA operations). By default, addresses 7 and 8 are used respectively for these virtual devices.

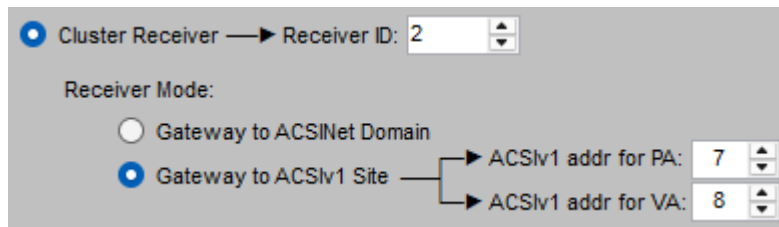

Figure 48: NEXO Hub Receiver to Site

NOTE: IDs may be the same between Senders and Receivers but must be unique within the same role.

A NEXO Hub belonging to a Cluster will not be able to enable the zone monitoring mode, 5.5.5 Zone Monitor Config.

(c) ACSINet Cluster Sender Live Monitor

Provides real-time monitoring of Cluster Sender devices when the NEXO Hub is configured as a Cluster Receiver.

ACSINet Cluster Senders Live Monitor					
Device Model	Cluster Sender ID	IP Address	Mics Count	Link Status	Talking
NEXO HUB	1	192.168.0.12	1	Ok	No
NEXO HUB	2	-	-	-	-

Figure 49: ACSINet Cluster Senders Live Monitor

- **Device Model:** Model of monitored device.
- **Cluster Sender ID:** Identifier of the sender.
- **IP Address:** IP address of the monitored device.
- **Mics Count:** Number of active microphones managed by the Sender.
- **Link Status:** Status of the sender's link. Its possible statuses are "Ok" if the connection to the device is successful, or "Error" if there is no connection to the device or it has been lost.
- **Talking:** Indicates whether any microphones connected to the monitored Sender are currently transmitting. Their possible statuses are "Yes" or "No".

(d) ACSINet Cluster Receiver Live Monitor

ACSINet Cluster Receivers Live Monitor									
Device Model	Cluster Receiver ID	IP Address	Domain ID	Domain Senders Number	Domain Concurrency	Domain Zones Count	Domain Groups Count	Link Status	Talking
NEXO HUB	1	192.168.0.9	2	2	2	5	12	Ok	No
NEXO HUB	2	192.168.0.10	1	0	1	7	12	Ok	No

Figure 50: ACSINet Cluster Receivers Live Monitor

- **Device Model:** Model of monitored device.
- **Cluster Sender ID:** Identifier of the sender.
- **IP Address:** IP address of the monitored device.
- **Domain ID:** ACSINet domain to which the monitored NEXO Hub Receiver belongs.
- **Domain Senders Number:** Number of Sender devices in the monitored Domain.
- **Domain Concurrency:** Concurrency configured in the Domain, maximum number of simultaneous microphones that can transmit speech.
- **Domain Zones Count:** The number of zones configured within the Domain.
- **Domain Groups Count:** The number of groups configured within the Domain.
- **Link Status:** Status of the sender's link. Its possible statuses are "Ok" if the connection to the device is successful, or "Error" if there is no connection to the device or it has been lost.
- **Talking:** Indicates whether any microphones connected to the monitored Sender are currently transmitting. Their possible statuses are "Yes" or "No".

(e) ACSINet Cluster Audio Live Monitor

This function enables the monitoring of the status of the multicast audio stream that is shared by the cluster. It facilitates the detection of conflicts or saturations in the audio channel shared by the Cluster, helping to diagnose problems related to concurrency or signal loss.

ACSINet Cluster Audio Live Monitor					
Audio Stream	IP Address	Active	Device Talking	Mic Model	Mic Address
Stream 1	239.98.7.7	Yes	Cluster Sender #1	MPS8Z+	ACSINetAddr #2

Figure 51: ACSINet Cluster Audio Live Monitor

- **Audio Stream:** Label of the audio stream.
- **IP Address:** Multicast IP address used to send audio.
- **Active:** Indicates if audio is active. Their possible statuses are "Yes" or "No".
- **Device Talking:** ID of the current computer that is speaking.
- **Mic Model:** Model of the microphone transmitting.
- **Mic Address:** ACSI address of the active microphone.

5.5.3 Local ACSI Bus Config

The "ACSI Local Bus" section allows you to manage the devices connected to the ACSI bus of the NEXO system, facilitating their detection, installation and monitoring within the system.

The settings for the following parameters can be accessed by pressing the "Open Edit Mode" button.

ACSIAddr	Supervised	Mic Model	FW Version	Link Status	Mic Status	Description
1	<input checked="" type="checkbox"/>	MPS8Z	v02.02	Linked	Ok	
2	<input type="checkbox"/>	VAP1	-	Missing	-	
3	<input type="checkbox"/>	MPS8Z+	v02.02	Plug & Play	-	
4	<input checked="" type="checkbox"/>	MPS8Z+	-	Missing	No-link	
32	<input type="checkbox"/>	MPS8Z	-	-	-	Controlled by ACSINet Virtual Mic 1

Figure 52: Local ACSI Bus

(a) Local ACSI Bus Configuration

The top of the window shows the local bus configuration mode:

- **Enable Plug and Play:** If enabled, the system will automatically detect ACSI devices connected to the bus. If disabled, devices will need to be manually installed by assigning them a specific address.
- **Bus topology:** Allows the connection topology of the device's local ACSIV2 bus to be selected.
 - **Single-branch (port ACSI 1):** Factory configuration. The ACSIV2 bus operates through a single branch of devices connected to the ACSI BUS 1 port of the NEXO device.

- **Dual-branch (ports ACSI 2A + 2B):** Allows operation with two independent ACSIv2 branches, connected to the ACSI BUS 2A and 2B ports of the NEXO device. This mode allows star distribution through two separate branches, simplifying the wiring.

NOTE: The bus capacity remains 32 addresses shared between both branches.

In Dual-branch mode, the ACSI 1 and ACSI 2 ports invert their input/output direction at audio and ACSI level. Before modifying the bus topology, review the physical wiring of the system. See section 2.2.4(d) ACSI BUS.

(b) Local ACSI Bus Device

At the bottom of the window is the list of ACSI devices currently connected to NEXO. If we access the edit mode, the following parameters can be configured for each ACSI address:

- **ACSI Addr:** Addresses available within the ACSI bus. Determines the assigned address of the ACSI microphone on the bus. Up to 32 addresses available.
- **ACSI Port:** Indicates the ACSI port or branch on which the device is installed.
- **Installed:** Assigns this address to an ACSI device within the bus.
- **Supervised:** Allows you to enable or disable device monitoring, as long as it is installed. If monitoring is enabled, the System Controller will report a fault if the physical device is not detected on the ACSI bus in the specified direction.
- **Mic Model:** Model of the connected device. The microphones available are:
 - **MPS8Z and MPS8Z+:** Microphones for General Public Address (PA)
 - **VAP1:** Emergency microphone (VA).
 - **VAP1FES:** Emergency microphone (VA) adapted to German regulations.
- **FW Version:** Firmware version of the connected ACSI device.
- **Link Status:** Displays the status of the ACSI device within the bus
 - **Plug & Play:** The device has been automatically detected.
 - **Linked:** The device has been manually installed and is correctly paired.
 - **Missing:** The device has been manually installed but has not been detected on the network.
- **Mic Status:** Current status of the microphone with active monitoring. In case of microphones detected via the "Plug & Play" function and not installed, their status will not be monitored and the field will appear empty. Possible status are:
 - **Ok:** The device is working properly.
 - **Talking:** The device has the floor granted and is emitting audio through the bus.
 - **Error:** The ACSI device is failing.
 - **No-Link:** The device has been manually installed and monitored but has not been detected on the network.
- **Description:** An editable field to add a custom description of the device.

NOTE: In case there are ACSINet profiles configured in the system driver, these will be applied to ACSI devices that share an address within the same ACSINet domain.

(c) ACSINet Mic Talk Operator Logger

The “ACSINet Mic Talk Operator Logger” window displays the status of the microphones within ACSINet communications after a request to speech has been made.

Talk Status	Talk Start Timestamp	Mic Addr	Talk Request Result	Talk Stop Timestamp	Talk Stop Reason
Talking	27/05/2025 12:20:47	Addr: 2 (MPS8Z+)	Accepted	-	-
IDLE	27/05/2025 12:20:38	Addr: 2 (MPS8Z+)	Denied (locally blocked)	-	-
IDLE	27/05/2025 12:20:35	Addr: 1 (MPS8Z)	Accepted	27/05/2025 12:20:42	Talk Stop
IDLE	27/05/2025 12:20:17	Addr: 1 (MPS8Z)	Denied (no link to ACSINet)	-	-

Clear Talk Logger

Figure 53: ACSINet Mic Talk Operator Logger

- **Mic Addr:** Shows the address and model of the microphone that made the request. When it is not possible to identify the model, no data will be displayed.
- **Current Status:** Shows the status of the microphone.
 - **IDLE:** The microphone is in a idle state.
 - **Talking:** The microphone is talking.
 - **Talking Request:** The microphone has made a speech request and is waiting for a response.
- **Talk Request Timestamp:** Displays the date and time the request was made.
- **Talk Request Result:** Displays the result of the speech request, the available statuses are as follows:
 - **"-":** Unknown status of the result of the speech request.
 - **Accepted:** The speech request has been accepted.
 - **Denied (locally blocked):** The speech request has been denied because there is a microphone with higher priority transmitting on the bus.
 - **Denied (no link to ACSINet):** The speech request has been denied because there is no ACSINet link to the rest of the system.
 - **Denied (remotely blocked):** The speech request has been denied remotely, either by a NEO+ or by a NEXO Receiver (cluster).
 - **Denied (concurrency limited):** The speech request has been denied because the cluster's concurrency has been exceeded.
- **Talk Stop Timestamp:** Displays the date and time when the request was terminated.
- **Talk Stop Reason:** Shows the reason why the request was terminated.
 - **Talk Stop:** The microphone has voluntarily stopped talking.
 - **Fired:** The microphone has stopped talking because it has been ejected from the bus.

5.5.4 Virtual Mic Mode

The “Virtual Mic” mode allows virtualizing a microphone or analog input connected to a NEXO, allowing audio to be transmitted via ACSINet.

These inputs behave in an equivalent way to an MPS8Z in terms of priority management, word request and triggers activation, respecting the priorities configured in the ACSINet profiles defined in NEO+.

This functionality is available in NEXO units configured as Sender and allows using the unit's physical audio inputs as a virtual microphone source.

- **Virtual ACSI Mic 1:** Uses the CH1 Analog Audio In channel as audio source. It can be configured as “Generic Mic” or as “A1 Mic Bus”.
- **Virtual ACSI Mic 2:** Uses the ACSI 1 BUS channel as the audio source. It can be set only as "Generic Mic".
- **Tigger Launch:** Uses GPIO ports as trigger launchers associated with an ID button.

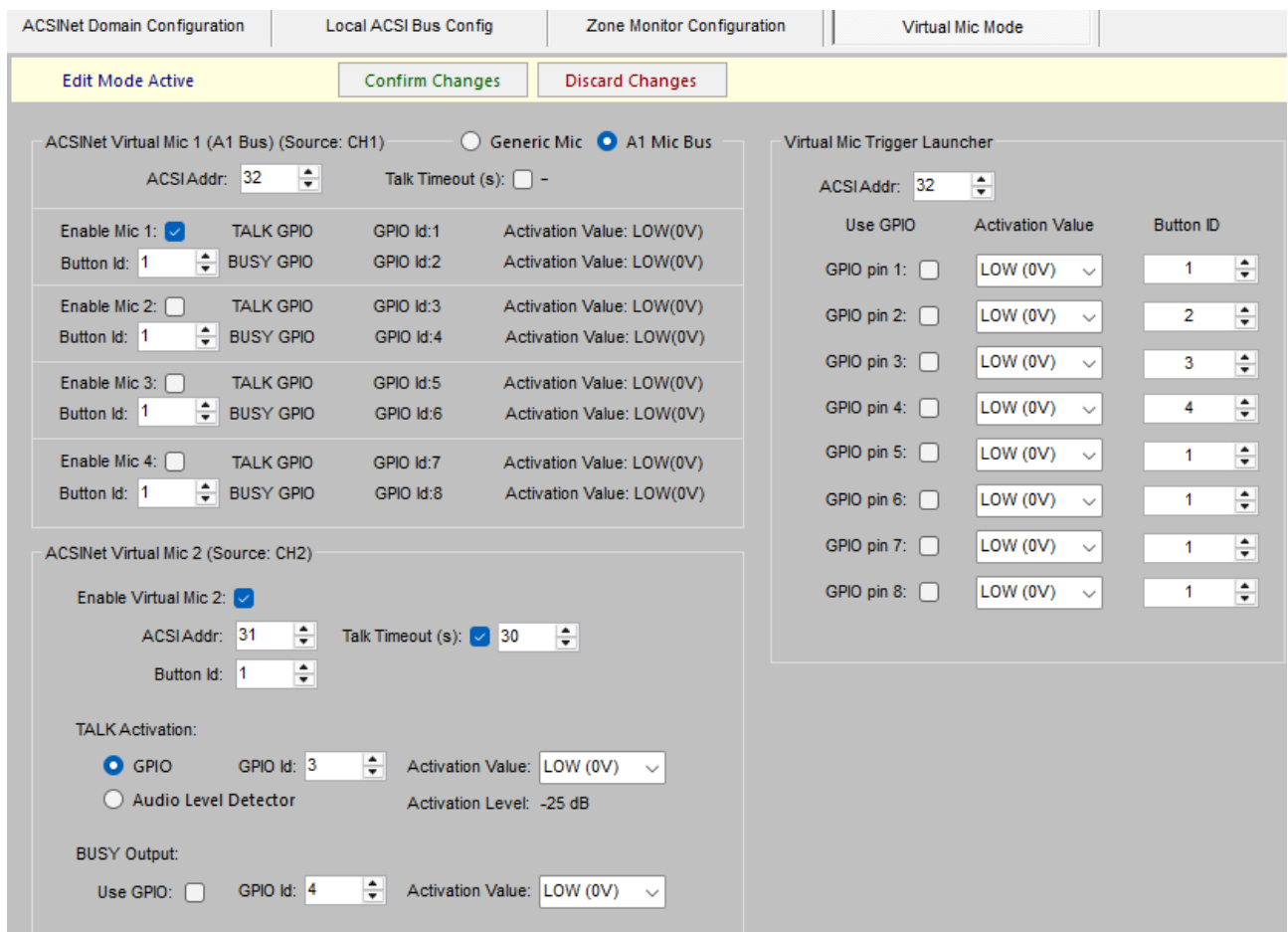

Figure 54: Virtual Mic Mode

(a) Generic Mic

This option allows the implementation of up to 2 generic virtual microphones.

These function as an MPS8Z within the system, allowing speech request by GPIO detection or by audio level (noise gate). The configurable parameters for each channel are:

- **Enable Virtual Mic:** Enables or disables the virtual microphone functionality on the channel.
- **Talk Timeout(s):** The maximum time in seconds that the microphone can hold the word before automatically going into busy state. It can be configured from a minimum of 30 seconds, the default value, to a maximum of 600 seconds.
- **Button ID:** Identifier of the button assigned in the NEO+ system for the activation of zones or groups, simulating the behavior of an MPS8Z.
- **ACSI Addr:** ACSI address assigned to the virtual microphone.
- **TALK:** Allows to select the speech request activation mode:
 - **GPIO:** Speech request by activation input signal on GPIO.
 - **GPIO Id:** Activation GPIO. Configurable from 1 to 8.
 - **Activation Value:** Setting the activation level of the request, LOW (0V) or HIGH (5V).
 - **Audio Level Detector:** Speech request is made when the sound level threshold configured from DSP Config (Activation Level) is exceeded. See 5.4 DSP Config.

NOTE: If the "Enable Virtual Mic" option is disabled, the request mode changes of the "TALK" parameter will not be saved.

- **BUSY GPIO:** Once enabled, after requesting to speech, it will remain in idle state if speech is conceded to the microphone or it will change its value in case it is not conceded.
 - **GPIO Id:** Activation GPIO. Configurable from 1 to 8.
 - **Activation Value:** Setting the activation level of the request, LOW (0V) or HIGH (5V).

(b) A1 MIC Bus

This mode is available exclusively for the CH1 input channel and allows the integration of up to four LDA A1 microphones connected in series via GPIO. The implementation uses the eight GPIO pins of the unit (GPIO 1 to 8), reserving two pins per microphone: one for speech request (TALK) and one for busy status (BUSY). This assignment is non-editable, and the activation is always done at low level (LOW, 0V).

For more information on connection and configuration of the A1 microphone consult its user manual available on the [LDA Support website: A1 User Manual](#).

See Appendix IV Pinout A1.

The ACSI address is common to all microphones on the bus, and each can be configured with a separate button identifier, allowing it to be assigned in NEO+ to different zones or groups. The system ensures that only one microphone on the bus has conceded speech, setting the others as busy automatically during the speech.

The configurable parameters are:

- **ACSI Adrr:** ACSI address shared between all microphones. By default, value 32 is set.

- **Talk Timeout(s):** The maximum time in seconds that the microphone can hold the word before automatically going into busy state. It can be configured from a minimum of 30 seconds, the default value, to a maximum of 600 seconds.
- **Enable Mic X:** Allows you to individually turn each virtual microphone on or off within the bus.
- **Button Id:** Identifier of the button assigned in the NEO+ system for the activation of zones or groups, simulating the behavior of an MPS8Z.

(c) Trigger Launch

This section facilitates the utilisation of GPIOs as event triggers via virtual buttons on an MPS8Z:

- **ACSI Addr:** ACSI address shared by all triggers.
- **GPIO pin X:** Allows to activate the pin as trigger.
- **Activation Value:** LOW (0V) or HIGH (5V) to define the level that triggers the event.
- **Button ID:** Defines the simulated button that will be sent to the system as if it had been pressed on an MPS8Z.

This allows to automate events or activations in the system without the need of a physical microphone.

NOTE: If multiple functions are assigned to a single GPIO, confirming the changes will display an error message indicating that GPIO is busy. The system will reject the configuration and return the user to the edit screen to correct the conflict.

5.5.5 Zone Monitor Config

The "Zone Monitor Configuration" section allows you to enable system zone monitoring using a loudspeaker connected to NEXO's physical CH1, Output 1. This function allows you to verify in real time the audio that is being transmitted in different areas of the system without the need to be physically in them. This facilitates the supervision of the public address system.

This function is activated by an MPS8Z+ microphone, which will act as a control device.

NOTE: When activating the zone monitoring function, Output 1 will automatically become controlled via ACSINet and the "Audio Config" settings will be ignored

To activate this function, we must access the editing mode through the "Open Edit Mode" button and activate the "Enable Zone Monitor on CH1 Output" option. The settings menu will then appear on the screen:

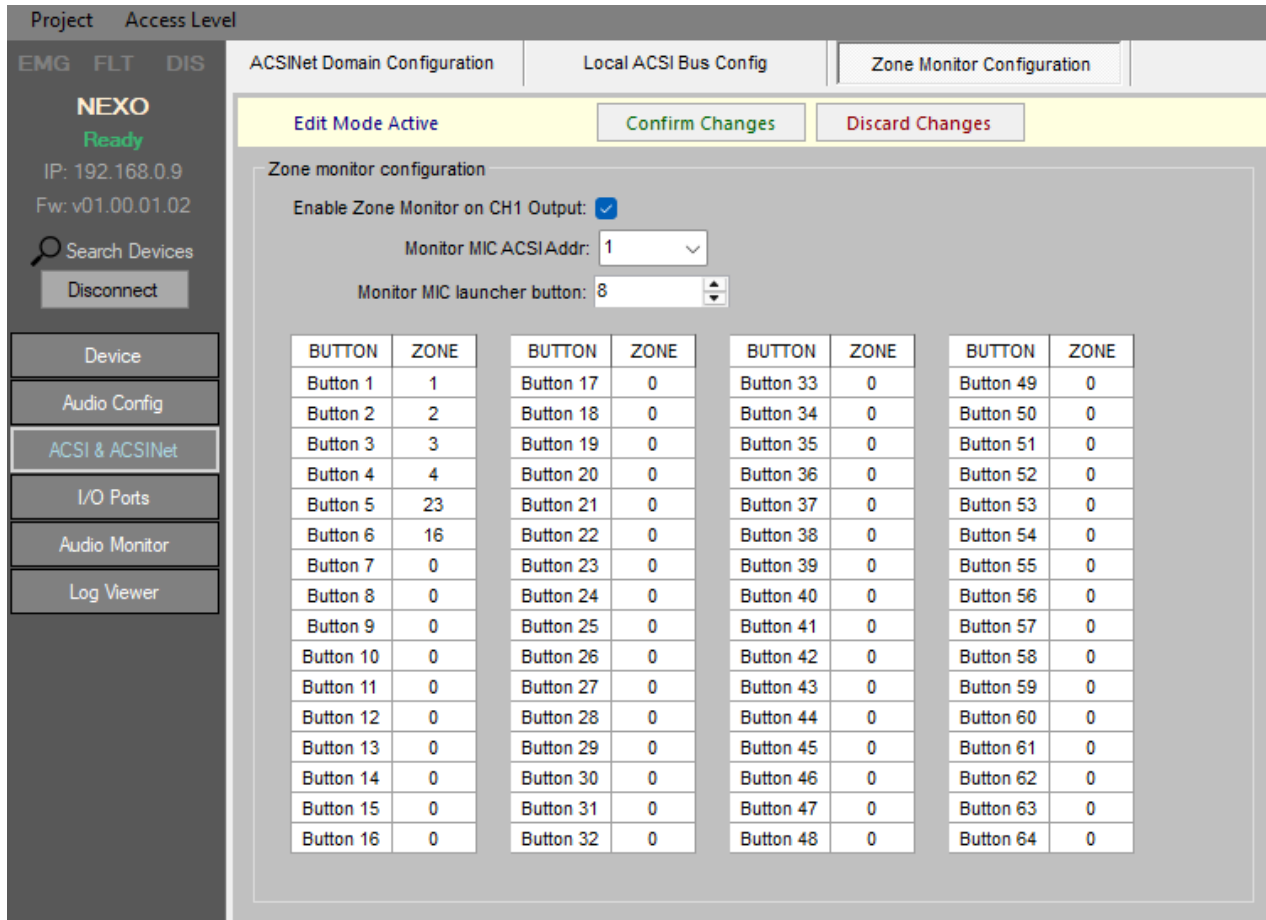

Figure 55: Zone Monitor

- **MIC ACSI Addr Monitor:** Defines the ACSI address of the MPS8Z+ that will trigger the monitoring function. Only a microphone on the bus can activate this function.
- **Monitor MIC Launcher Button:** Sets the button on the MPS8Z+ that will activate the monitoring function. This button cannot be assigned to any other function within the system.

In the table, each button on the MPS8Z+ can be assigned for monitoring of a specific zone, up to a maximum of 64.

NOTE: An MPS8Z+ has a total of 8 zone buttons, so MPS8K+ expansion keyboards must be added, up to a maximum of 7. Each keyboard adds 8 extra zone buttons, making a total of 64 zones.

To run the monitor function, on the MPS8Z+ microphone, press the EVENT button, then press the button previously defined as "MIC Launcher" and the zone button you want to monitor. Press the "Talk" button to confirm the execution.

To stop monitoring, on the MPS8Z+ microphone, press the events button, then the button previously defined as "MIC Launcher". Press the "Talk" button to stop the function. In case the function is not manually stopped, it has a timeout of 90 seconds, which will stop the monitoring automatically.

5.6 I/O Ports

The I/O Ports tab allows you to configure the input and output interfaces available on the NEXO, such as GPIO ports and RS232 communication.

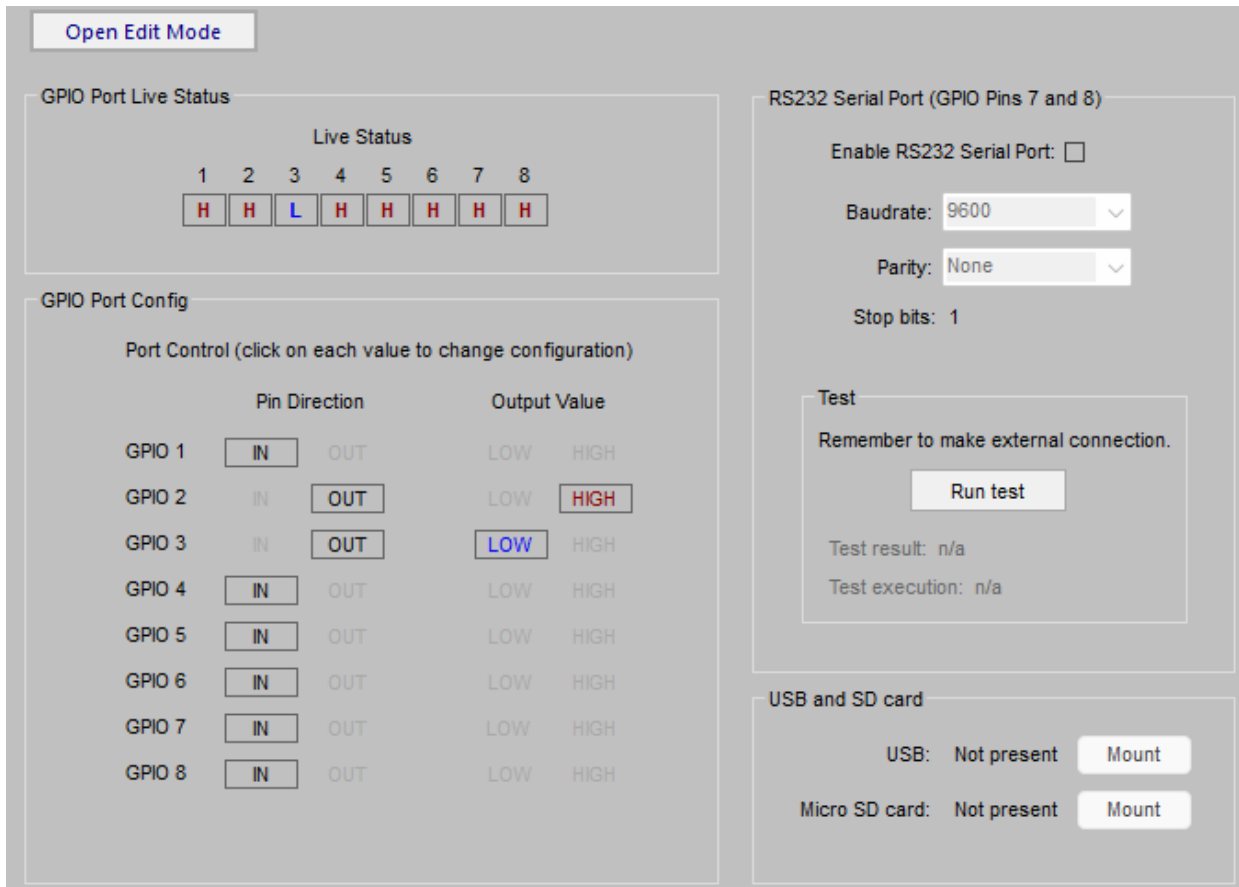

Figure 56: I/O Ports

5.6.1 GPIO Port

GPIO (General Purpose Input/Output) ports allow interaction with external devices for system control and monitoring. Each of the 8 pins can be configured as input or output according to the needs of the system by accessing through the "Open Edit Mode" button.

- **Live Status:** Displays the current status of pins 1 through 8, indicating whether they are on High (H) or Low (L).
- **Pin Direction:** Each GPIO can be individually configured as an input (IN) or output (OUT) independently by clicking on the corresponding value or simultaneously with the "All as INPUT" and "All as OUTPUT" buttons.
- **Output Value:** Allows you to set the activation status of the pins configured as Output at high (HIGH) and low level (LOW) independently by clicking on the corresponding value or simultaneously with the "All to LOW" and "All to HIGH" buttons.

5.6.2 RS232 Serial Port

This section allows advanced configuration of the RS232 interface, used for connection with external devices that require serial communication for system control.

The RS232 interface shares pins 7 and 8 of the GPIO port. To use it, it is necessary to activate the "Enable RS232 Serial Port" option, which disables any previous configuration on these pins within the GPIO section.

- **Baudrate:** Defines the data transmission rate, with a default value of **9600 bps**.
- **Parity:** Allows you to select the type of parity (None, Even, Odd).
- **Stop bits:** Configures the number of stop bits in the communication.

The "Test" option allows you to verify the RS232 connection with an external device before use.

5.7 Power Config

From this window, supervision of the device's local power inputs can be enabled and GPIO inputs can be assigned to supervise and receive status signals from the external EN54-4 power supply. The detected faults will be shown in "Live Errors Monitor", will be recorded in "Log Viewer" and will be notified to the NEO+ system.

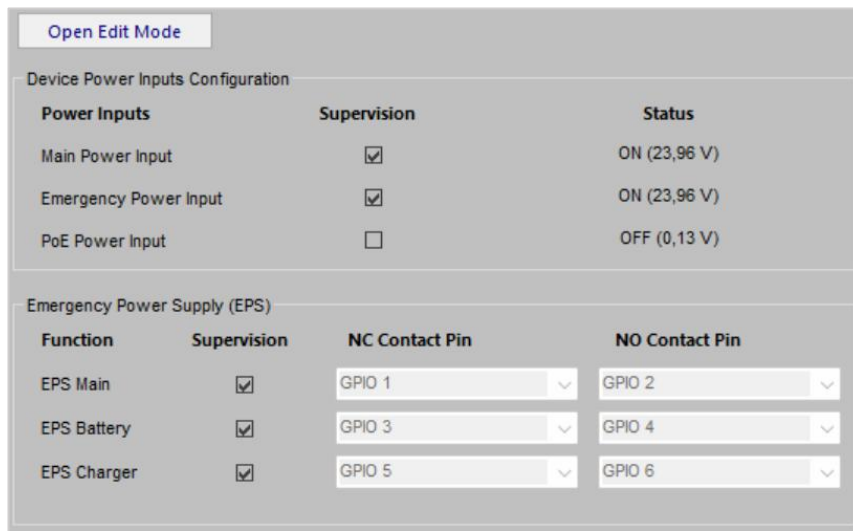

Figure 57: Power Config

5.7.1 Device Power Inputs Configuration

Allows the local power inputs of the NEXO device to be supervised.

- **Main Power Input:** Main power input of the device.
- **Emergency Power Input:** EPS emergency power input (Emergency Power Supply).
- **PoE Power Input:** Power input via Power over Ethernet through the compatible Ethernet port.

For each input, the following fields are shown:

- **Supervision:** Allows the supervision of the corresponding power input to be enabled or disabled. If supervision is enabled and the device stops receiving voltage through that input, NEXO will generate a local fault.
- **Status:** Shows the actual status of the power input. The status can be ON, when power is being received through that input, or OFF, when no power is detected. Together with the status, the voltage measured in real time is shown.

5.7.2 Emergency Power Supply (EPS)

Allows configuration of the status supervision of an external EN54-4 charger through contact closures connected to the GPIO of the NEXO device.

The supervisable functions are:

- **EPS Main:** Supervision of the main input power status of the external charger.
- **EPS Battery:** Supervision of the battery status of the external charger.
- **EPS Charger:** Supervision of the output power status of the external charger.

For each function, the following fields are shown:

- **Supervision:** Enables or disables supervision of the corresponding EPS function.
- **NC Contact Pin:** Allows assignment of the GPIO used to supervise the normally closed contact of the EPS function.
- **NO Contact Pin:** Allows assignment of the GPIO used to supervise the normally open contact of the EPS function.

Depending on the external charger model used, supervision can be performed through a single NC or NO contact, or through both contacts. For this reason, NEXO allows one or two GPIO to be configured for each EPS function, adapting to the type of supervision output available in the charger.

NOTE: The GPIO assigned to EPS functions are reserved for supervision of the external charger and cannot be used simultaneously for other device functions, such as general-purpose GPIO, Virtual Mic, Trigger Launch or RS232.

5.8 AES67 Module

The "Audio Monitor" tab allows you to view in real time the audio status in the NEXO system, including the signal level at the inputs and outputs, the status of PTPv2 synchronization, and the monitoring of AES67 audio streams.

This section is an essential diagnostic tool for monitoring audio status, verifying system synchronization, and monitoring the quality of audio streams in real time.

The screenshot shows the NEXO Audio Monitor interface. On the left is a sidebar with navigation options: Device, Audio Config, ACSE & ACSINet, I/O Ports, Audio Monitor (selected), and Log Viewer. The main area displays several sections:

- Physical Vumeters [dB]:** A table showing signal levels for Line Input 1 (-56), Line Input 2 (ACSI) (-32), Line Output 1 (-34), and Line Output 2 (ACSI) (-100).
- PTPv2 Runtime Status:** A table with columns for Status, Identity, Master Identity, Offset (ns), Delay (ns), and Reset Count. The status is SLAVE with a reset count of 29.
- AES67 Rx Slots:** A table with columns for Link, Local Vumeter, Streamid, Streamip, StreamPort, Channel, Encrypted, QORS1, QORS2, QORS3, Lost, and Out Of Time. The first slot is active with a local vumeter of -68.
- AES67 Tx Slots:** A table with columns for Transmit, Local Vumeter, Stream Id, Stream IP, Stream Port, Encrypted, SAP Announce, Ch. Num, Out Of Time, and Send Fails. The first slot is active with a local vumeter of -34.
- Control:** A button labeled "Reset AES67 Stats".

Figure 58: Audio Monitor

5.8.1 PTPv2 Config

The PTPv2 protocol synchronizes the devices that broadcast and/or receive audio streams. It is crucial that NEXO shares the PTP IP and domain values with all devices that receive or transmit AES67 audio on the same network.

It is recommended to use the system with the default parameters, although these are editable in case the system specifications require it.

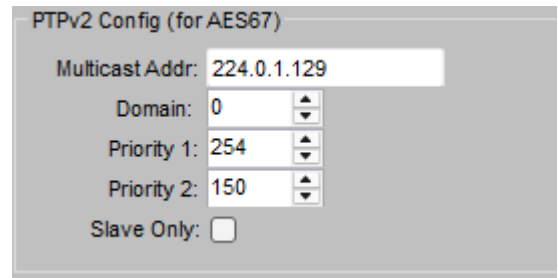

Figure 59: PTPv2 Config

5.8.2 Physical Vumeters [dB]

This section shows the signal levels in dB of the physical audio inputs and outputs of NEXO:

- **Line Input 1:** Signal level on the analogue input CH1.
- **Line Input 2 (ACSI):** The signal level at the input coming from the ACSI bus.
- **Line Output 1:** Signal level of the analogue output CH1.
- **Line Output 2 (ACSI):** The signal level of the ACSI bus audio output (not implemented).

5.8.3 PTPv2 Runtime Status

The PTPv2 (Precision Time Protocol) protocol is used for clock synchronization between devices on the network. This section shows the current status of NEXO synchronization:

- **Status:** Indicates whether NEXO acts as a SLAVE (sync receiver) or MASTER (sync source). Other possible states are: INITIALIZING, FAULTY, DISABLED, LISTENING, PRE_MASTER, PASSIVE and UNCALIBRATED.
- **Identity:** MAC address of the NEXO device.
- **Master Identity:** MAC address of the device that acts as the synchronization master.
- **Offset (ns):** Time difference in nanoseconds between NEXO and the clock master.
- **Delay (ns):** Delay in synchronizing time between devices.
- **Reset Count:** Number of synchronization protocol restarts.

Stable PTPv2 synchronization is essential to ensure audio transmission without interruptions or lags.

5.8.4 AES67 Tx Slots

Displays the status of audio streams streamed by NEXO using AES67. Each output stream includes the following parameters:

- **Transmit:** Indicates whether the stream is enabled.
- **Local Vumeter:** Signal level of the transmitted audio.

- **Stream ID:** Stream multicast identifier
- **Stream IP:** IP address of the configured multicast stream.
- **Stream Port:** Audio transmission port.
- **Encrypted:** Indicates whether the transmitted audio is encrypted.
- **SAP Announce:** If enabled, allows external devices to discover the stream.
- **Tx Channels:** Number of channels in the streaming stream.
- **Send Fails:** Number of failures in audio transmission.

5.8.5 AES67 Rx Slots

Displays the status of audio streams received using AES67. Each input stream is represented by the following parameters:

- **Link:** Indicates if there is an active connection with the received stream.
- **Local Vumeter:** Signal level of the received audio.
- **Stream ID:** Stream multicast identifier
- **Stream IP:** IP address of the configured multicast stream.
- **Stream Port:** Audio receive port.
- **Channel:** Audio channel within the stream.
- **Encrypted:** Indicates whether the received audio is encrypted.
- **QOR-J (Quality of Reception - Jitter):** Indicates the reception quality based on the variation in latency between packets.
 - **100:** No perceptible jitter.
 - **<100:** Jitter is present. The lower the value, the worse the quality.
- **QOR-S (Quality of Reception - Synchronization):** Indicates the synchronization quality of the received RTP packets relative to the network's PTP clock.
 - **100:** All packets arrive on time.
 - **<100:** Some packets arrive out of time and are discarded.
- **Lost (RTP seq):** Number of packets lost in transmission.
- **Drop (Out Of Time):** Number of audio packets received out of time.

5.8.6 Control

The "Reset AES67 Stats" button allows you to reset the status counters of AES67 streams (lost packets, sync errors, etc.).

5.9 Ethernet Monitor

The “Ethernet Monitor” tab allows the Ethernet traffic counters of the NEXO device to be viewed in real time. This window is intended for advanced communications diagnosis, showing the traffic received and transmitted by the external Ethernet ports and by the internal communication port with the device processor (MCU).

Ethernet Switch Ports					
Port	Link	Rx Count	Tx Count	Rx Dropped	Tx Dropped
1 [Port A]	<input checked="" type="checkbox"/>	4	3073	0	0
2 [Port B]	<input checked="" type="checkbox"/>	2066	1021	0	0
3 [MCU]	<input checked="" type="checkbox"/>	1017	2071	0	0

Processor ENET Rx Stats					
IRQ Count	MAC Count	FW Count	FW Drop(Overflow)	FW Drop(Error)	FW Drop(Firewall)
41	2068	42	0	0	4

General Info	
IGMP Querier:	Missing
PTPv2 Link:	Up

Figure 60: Ethernet Monitor

5.9.1 Ethernet Switch Ports

Shows the status and traffic counters of the ports of the NEXO internal Ethernet switch.

- **Port:** Identifies the monitored port. The available ports are:
 - **Port A:** Ethernet port A of the device.
 - **Port B:** Ethernet port B of the device.
 - **MCU:** Internal communication port between the Ethernet switch and the NEXO main processor. It does not correspond to an external port.
- **Link:** Indicates whether there is an active link on the corresponding port.
- **Rx Count:** Number of packets received by the port (transmitted by the MCU).
- **Tx Count:** Number of packets transmitted by the port (towards the MCU).
- **Rx Dropped:** Number of packets received by the port that have been discarded.
- **Tx Dropped:** Number of packets that could not be transmitted by the port and have been discarded.

The traffic received from the network by external ports A or B is transmitted to the internal MCU port when applicable. Likewise, the traffic received from the internal processor through the MCU port is transmitted to the Ethernet ports of the device.

5.9.2 Processor ENET Rx Stats

Shows the reception counters of the NEXO internal Ethernet processor, within its MCU.

- **IRQ Count:** Number of Ethernet reception interrupts.
- **MAC Count:** Number of packets received by the MAC controller of the processor.

- **FW Count:** Number of packets accepted by the NEXO firmware after internal filtering.
- **FW Drop (Overflow):** Number of packets discarded due to internal overflow.
- **FW Drop (Error):** Number of packets discarded due to error.
- **FW Drop (Firewall):** Number of packets discarded by the internal filtering of the device.

5.9.3 General Info

Shows general information about the network status of the device.

- **IGMP Querier:** Indicates whether NEXO detects an IGMP Querier on the network.
- **PTPv2 Link:** Indicates the PTPv2 synchronization status of the device.

5.10 Log Viewer

The "Log Viewer" tab allows you to view and manage system logs in NEXO. These logs include events, detected errors, and device connection states, providing an essential tool for system diagnostics and maintenance.

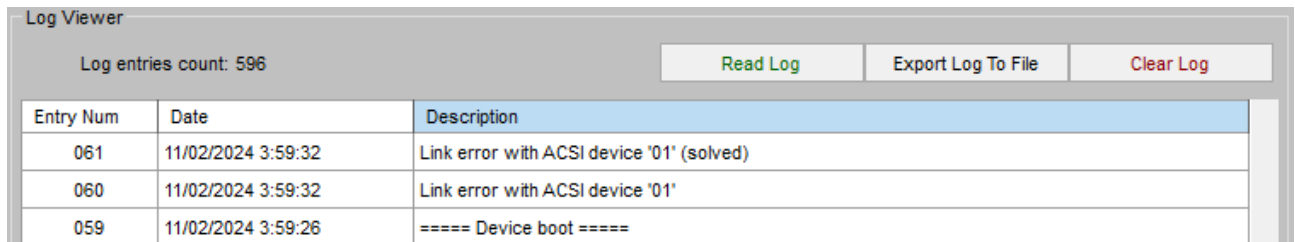

Figure 61: Log Viewer

- **Read Log:** Reloads logs stored on the system to show the most recent events.
- **Export Log To File:** Allows you to export the event log to an external file for analysis or storage.
- **Clear Log:** Clears all logs stored on the system.

6 MAINTENANCE INSTRUCTIONS

The equipment requires reduced periodic maintenance.

The frequency of maintenance must be adjusted according to the installation conditions of the equipment. At least it is advisable to establish a maximum period of one year.

Operations:

- Clean the air inlets and outlets of the equipment with a vacuum cleaner.
- Check the equipment connections and the ground connection.

Warnings:

- Use only soft, lint-free cloth.
- Disconnect your device from any external power source.
- Disconnect all external devices.
- Keep the product away from any liquid.
- Do not use aerosols, solvents or abrasive substances.
- Do not spray any cleaner directly onto the appliance

7 SPECIFICATIONS

MODEL	NEXUS
Reference	LDANEXOS02
Power Supply	100 - 240V ~ Adapter to 24Vdc/0.5A included
Input EN54-4	20-28 VDC / 0.2-1A for EN54-4 charger. Euroblock 2p
Power consumption	5W typical. Maximum 15W (ACSI devices)
Frequency Response	20Hz-20kHz +/-0.05dB
Signal-to-noise ratio	SNR > 93dB
Distortion	<0.05%
DSP	2 x 2 48kHz, 28bit – 50 MIPS matrix
Phantom Power supply	24Vdc CH1 input
Ethernet	2 x 100Mbps/s RJ-45 female Ethernet ports with loop function. Port A with PD PoE 12W IEEE802.3at
MicroSD	1 x microSD Reader
General Control (GPIO)	8 x I/O Control, 0 – 5Vdc 100Ω / RS-232 "2 GPIO less". Euroblock 5p
Audio IP	AES67, 1ms, 48kHz, 24bits
Audio IN/OUT	1 x 1 input 10kΩ / output 100Ω - Balanced audio 1 Vrms. Euroblock 3p
LDA BUS ACSI	2 x ACSI ports, 1 with 10kΩ redundant capacity, RJ-45 female, total 1000m / 3280.84ft
Switch	2 x ACSI bus power input switch, one per ACSI port
USB	1 x Product Maintenance
Indicators	Status: Power on, breakdown, fault, emergency and USB detection
Bellboy	1 x reset, 1 x function
Dimensions (W x H x D)	220.9 x 42.7 x 121.2 mm / 86.96" x 16.81" x 47.71"
Operating conditions	-5 °C to +45 °C / 23 °F to 113 °F 5% to 95% Relative Humidity (non-condensing)
Finishing	Top: Material Fe - Grey colour RAL 7016 Base: Material Al - Natural color
Weight	0.75 kg

Appendix I. Network Configuration

FACTORY NETWORK SETTINGS

NEXO has the following factory default network settings:

- IP: 192.168.000.009
- Mask: 255,255,255,000
- Gateway: 192.168.000.100
- Flexnet Mode (VLANs) disabled by default.

MULTICAST IP ADDRESSING

Service	IP address	MAC Address
LDA Discovery Service	224.0.2.11	01:00:5E:00:02:0B
PTPv2	224.0.1.129	01:00:5E:00:01:81
Multicast IGMP	224.0.0.1	01:00:5E:00:00:01
LDA AES67 Streams (NEO+ and NEXOs02)	[232.1.1.100-232.255.1.100]	-

Table 10: IP Addressing

For more information on multicast addressing used in ACSINet, please refer to the information available on the [LDA Audio Tech Support website](#).

Appendix II. Network Specifications

NEXO is designed to integrate into advanced IP networks, using standard technology and protocols that ensure high-quality audio and data transmission. These features make the device highly versatile and compatible with complex public address and communication systems.

NETWORK COMPATIBILITY AND OPERATION

NEXO employs a standard Ethernet infrastructure that supports full-duplex connections at speeds of as little as 100 Mbps. It supports networks based on the AES67 protocol for audio transmission, ensuring a synchronized and high-fidelity stream.

The device also uses LDA's FlexNet standard, allowing simultaneous transmission of data and audio over two different VLANs. It is recommended to divide networks into VLANs to separate critical audio traffic from standard data traffic, especially in high-density configurations, improving efficiency and minimizing potential interference.

NOTE: FlexNet mode activation and VLAN configuration must be done from the NEXO Config Tool configuration application (see chapter 5.2.2 Network).

IP ADDRESS MANAGEMENT

NEXO can operate with a static IP address or through dynamic assignment via DHCP:

- Static IP address: Ideal for configurations where precise control over the network is required.
- DHCP (Dynamic Host Configuration Protocol): Allows the device to automatically obtain network parameters (IP, subnet mask, and gateway) from a DHCP server.

The default IP address and other specific details are located in the Appendix I Network Configuration.

SUPPORTED PROTOCOLS

NEXO uses a number of standard protocols to ensure synchronization, audio streaming, and network management.

(a) Precise Time Protocol (PTP)

Used for clock synchronization between devices on the network, it is essential for IP audio transmission under the AES67 standard. PTP ensures that the devices work at identical sample rates, selecting a master that synchronizes the slave devices.

A single PTP domain must be configured in each network or section, or the network must be divided into sections called PTP Boundaries, each with an independent master.

(b) Session Announcement Protocol (SAP):

SAP makes it easy to publish and discover active AES67 audio streams on the network, allowing devices to automatically connect to available streams.

(c) Multicast Management (IGMP):

IGMP is used to manage multicast group subscriptions, optimizing audio and data transmission on medium or large networks.

This protocol ensures efficient use of bandwidth by avoiding sending unnecessary data to non-subscribed devices.

NOTE: On large networks, make sure the switches support IGMP Snooping. An IGMP querier must be activated on the network and unregistered multicast traffic must be filtered in order to have correct bandwidth management.

(d) QoS and DSCP.

Quality of Service (QoS) allows you to prioritize critical network traffic, ensuring that AES67 audio data has lower latency, lower packet loss, and more stable transmission on congested networks.

For optimal operation, it is recommended that the network switches used in the system support QoS and DSCP prioritization. Traffic classification in AES67 uses the following priorities:

- PTPv2 (Precision Time Protocol) → DSCP 56 (Expedited Forwarding - EF) traffic, prioritizing audio synchronization.
- Audio AES67 RTP (Real-Time Protocol) → DSCP 46 (Assured Forwarding - AF41), ensuring quality in audio transmission.
- Control traffic → DSCP 00, ensuring correct communication between devices without interfering with audio streams.

(e) ACSINet

Used for communication between devices and audio transmission within the NEO+ system, employing specific multicast addresses.

Appendix III. Pinout Bus ACSI

Conector	Pin	Señal
	1	Audio +
	2	Audio -
	3	GND
	4	RS-485A
	5	RS-485B
	6	GND
	7	+24V
	8	+24V

Table 11: Pinout conector Bus ACSI RJ-45

Appendix IV. Pinout A1

Conector	Pin	Señal
	1	GND
	2	Audio -
	3	Audio +
	4	TALK
	5	BUSY

Table 12: Pinout conector A1 XLR-5

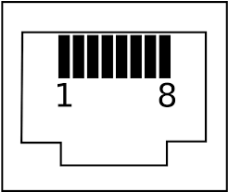
TABLE OF CONTENTS OF ILLUSTRATIONS

Figure 1: Indicators 8

Figure 2: Inputs and outputs..... 9

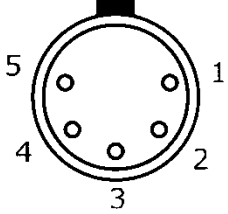
Figure 3: Ethernet Ports 10

Figure 4: microSD socket..... 10

Figure 5: NEXO Hub License card 10

Figure 6: Integration Ports 10

Figure 6: GPIO..... 11

Figure 7: RS232 11

Figure 8: CH1 Audio 11

Figure 9: ACSI Bus..... 12

Figure 10: Main power supply 13

Figure 11: Emergency Power..... 13

Figure 12: PoE Power..... 13

Figure 14: Parts supplied for rack mounting..... 14

Figure 15: Long fixing bracket assembly 15

Figure 16: Short fixing bracket assembly 15

Figure 17: Front view rackmount of a device 15

Figure 18: Short fixing bracket assembly 16

Figure 19: Side Junction Plate Mounting 16

Figure 20: Rear Attachment Plate Mounting 16

Figure 21: Two-device rackmount scheme 17

Figure 22: Short fixing bracket assembly 17

Figure 23: Wall Mount View 18

Figure 24: Flexnet Ring Integration with NEO+ 19

Figure 25: Multi-service network connection with NEO+ 19

Figure 26. Connection with ONE system..... 20

Figure 27: ACSINet System 21

Figure 28: ACSINET Domain..... 22

Figure 29: ACSINET Cluster..... 23

Figure 30: Example of Configuration, Virtual Mic - A1 Mic Bus 25

Figure 31: Login..... 26

Figure 32: NEXO Config Tool Interface..... 27

Figure 31: Device Info 29

Figure 34: Network..... 29

Figure 33: Device Date & Time 29

Figure 36: Update Custom Time 30

Figure 35: Tools..... 30

Figure 36: Live Error Monitor 30

Figure 39: Audio Config 31

Figure 40: Input channels 33

Figure 41: Controlled by ACSINet..... 34

Figure 42: DSP Config 35

Figure 43: Save to Config..... 36

Figure 44: ACSINet domain 37

Figure 45: ACSINet Cluster Configuration 38

Figure 46: NEXO HUB Local Configuration..... 39

Figure 47: NEXO Hub Receiver to Domain..... 40

Figure 48: NEXO Hub Receiver to Site 40

Figure 49: ACSINet Cluster Senders Live Monitor 41

Figure 50: ACSINet Cluster Receivers Live Monitor..... 41

Figure 51: ACSINet Cluster Audio Live Monitor 42
 Figure 52: Local ACSI Bus 42
 Figure 53: ACSINet Mic Talk Operator Logger 44
 Figure 54: Virtual Mic Mode 45
 Figure 55: Zone Monitor 48
 Figure 56: I/O Ports 49
 Figure 57: Power Config 50
 Figure 58: Audio Monitor 51
 Figure 59: PTPv2 Config 52
 Figure 60: Ethernet Monitor 54
 Figure 61: Log Viewer 55

TABLE OF CONTENTS

Table 1: Indicators 8
 Table2: Ethernet Ports 10
 Table 3: GPIO 11
 Table 4: RS232 11
 Table 5: CH1 Audio 11
 Table 6: ACSI Bus 12
 Table 7: Main power supply 13
 Table 8: Emergency Power 13
 Table 9: PoE 13
 Table 10: IP Addressing 58
 Table 11: Pinout conector Bus ACSI RJ-45 61
 Table 12: Pinout conector A1 XLR-5 61