

# User's Manual



**Model: MPS8Z+**

## TABLE OF CONTENT

<b>1 INTRODUCTION .....</b>	<b>5</b>
<b>2 DESCRIPTION .....</b>	<b>5</b>
2.1 INDICATORS.....	7
2.1.1 SYSTEM STATUS INDICATORS .....	7
2.2 CONTROLS .....	9
2.2.1 ADVANCED FUNCTION CONTROLS .....	9
2.2.2 CALL FUNCTIONS CONTROLS .....	10
2.3 INPUTS AND OUTPUTS.....	12
2.3.1 MIC.....	12
2.3.2 INPUT / OUTPUT FOR PUBLIC ADDRESS AND VOICE ALARM SYSTEM (ACSI BUS "LOOP").....	12
2.3.3 AUXILIARY POWER SUPPLY .....	13
2.3.4 PORTS FOR EXPANSION KEYBOARDS.....	13
<b>3 CONNECTION AND SETTING UP .....</b>	<b>13</b>
3.1 POWER SUPPLY.....	14
3.1.1 POWER SUPPLY SELECTOR .....	14
3.2 CONNECTION TO THE SYSTEM (ACSI BUS).....	15
3.3 ACSI BUS ADDRESS CONFIGURATION .....	15
3.3.1 BUS TERMINATOR .....	16
3.3.2 ACSI BUS VERSION ERROR DETECTION .....	16
3.4 MPS-8K+ EXPANSION KEYBOARDS INSTALLATION .....	17
3.4.1 KEYBOARD ID .....	18
3.5 BUSY BUS FEEDBACK .....	18
<b>4 OPERATION DESCRIPTION .....</b>	<b>19</b>
4.1 POWER ON .....	19
4.2 KEYBOARD LOCK.....	19
4.3 PAGING VOICE ANNOUNCEMENTS.....	19
4.4 ENDING THE CALL WITH THE CANCEL BUTTON .....	19
4.5 ZONE MEMORY SELECTION .....	20
4.6 ZONE MEMORY GROUP SELECTION .....	20
4.7 RECORDING ZONE MEMORY GROUP.....	20
4.8 DELETE MEMORY PRESELECTIONS.....	21
4.9 LOCKING OF UNUSED ZONE BUTTONS .....	21
4.10 STORE & FORWARD .....	21
4.11 RECALL .....	22
4.12 BUSY ZONE/GROUPS REQUEST .....	22
4.13 SYSTEM EVENT.....	23
4.13.1 LAUNCHING SYSTEM EVENTS .....	23

4.14	POWER-SAVING MODE.....	23
<b>5</b>	<b>MPS8Z+ PERFORMANCE-BASED CONFIGURATIONS.....</b>	<b>24</b>
5.1	CONFIGURATION OF TALK BUTTON .....	24
5.2	CONFIGURATION CHIME .....	24
5.3	CONFIGURATION OF EXTERNAL MICROPHONE .....	24
5.4	CONFIGURATION DSA FUNCTION .....	25
5.5	CONFIGURATION OF LOCK & POWER-SAVING.....	25
5.6	CONFIGURATION OF STORE & FORWARD and RECALL .....	25
5.7	CONFIGURATION OF OUTPUT VOLUME .....	26
5.8	PERMANENT STORAGE.....	26
5.9	FACTORY RESET .....	26
<b>6</b>	<b>UPDATE .....</b>	<b>27</b>
<b>7</b>	<b>FAULT RESOLUTIONS .....</b>	<b>28</b>
7.1	THERE IS NO LINK WITH THE SYSTEM.....	28
7.2	STATE LED INDICATORS BLINK SIMULTANEOUSLY.....	28
7.3	FLT AND LINK LEDS BLINK ALTERNATELY .....	28
7.4	NO LED INDICATOR IS ON .....	28
7.5	THE VOICE ANNOUNCEMENT IS VERY LOUD/LOW .....	29
7.6	IS NOT POSSIBLE TO HEAR THE VOICE ANNOUNCEMENT .....	29
7.7	THE EXPANSION KEYBOARD DOES NOT ADDRESS THE SELECTED ZONES.....	29
7.8	THE EXPANSION KEYBOARD DOES NOT SWITCH ON.....	30
<b>8</b>	<b>MAINTENANCE INDICATIONS .....</b>	<b>31</b>
<b>9</b>	<b>TECHNICAL SPECIFICATIONS .....</b>	<b>32</b>

## SAFETY INSTRUCTIONS

- 1 Keep this User Manual for future reference.
- 2 Unplug the unit from the power outlet before cleaning it.
- 3 Do not put containers containing liquids on the device. Do not pour liquids on the unit.
- 4 Install this equipment on a safe surface. If the equipment is not placed on a safe surface, it may fall and be damaged.
- 5 Do not place flame sources over the equipment, such as candles.
- 6 Always keep in mind all warnings and precautions of the equipment.
- 7 Never open the equipment. For safety reasons, the equipment should only be manipulated by qualified personnel.
- 8 Pay attention to the connection polarity, when operating the equipment with a direct current (DC) power source. The reversed polarity connection can cause damage to the equipment or to the power supply.
- 9 If any of these situations arise, let the technical staff check the equipment:
  - a) The power cord or plug is damaged.
  - b) Liquid has penetrated inside the equipment.
  - c) The equipment has been exposed to moisture.
  - d) The equipment has not worked well or does not work according to the instruction manual.
  - e) The equipment has dropped and been damaged.
  - f) If the equipment has obvious signs of damage.
- 10 Disconnect the audio inputs and outputs while making the connections. Be sure to use the appropriate cables to make the connection.

## 1 INTRODUCTION

The series of MPS+ paging stations is designed to provide the system with high-quality public address and performance microphones. The expansion keyboards available, allow it to adjust to the particularities of each system in terms of zones.

## 2 DESCRIPTION

The microphone desk MPS8Z+ allows to give live voice announcements messages for up to 64 memories of selection of public address zones of a NEO system.

## FUNCTIONS

1. 8 zone memory keys on the main unit, which allow calling a zone or multiple zones from each button.
2. Up to 56 additional selection keys (through the use of expansion keypads).
3. 8 memories for system events.
4. ACSI v2 protocol allows up to 32 devices on the bus.
5. "Store & Forward" functionality.
6. Information on busy zones, with pre-evaluation function.
7. Recall functionality (from the latest live PA message up to 45 seconds)
8. Ding dong (chime)
9. External microphone input.
10. Volume adjustment.
11. System evacuation status indicator.
12. System failure status indicator.
13. Status indicator of link with the system.
14. Zone memory selection indicator.
15. Word indicator granted.
16. Busy line indicator.
17. 8 Zone memory selection indicators.
18. Keypad lock.
19. Zone memory pre-selection memory.
20. DSA ("Dynamic Sound Adjuster")
21. Advanced event control with multi-trigger options.

## INTEGRATION WITH ACSI V2 PROTOCOL

The new version of the ACSI protocol has been recently released with the firmware v02.40.xx.xx of NEO devices. This new version has been integrated on the v02.xx version of the MPS8Z+, taking advantage of its better capabilities and new features.

The ACSI v2 protocol brings many improvements over its former version v1. Some of them, especially those affecting the MPS+, are listed below:

- ✓ Up to 32 devices on the bus
- ✓ Faster link process
- ✓ Added “groups” functionality. It allows to define groups of zones that can be used all across the system
- ✓ Improved customization of the zone buttons with the use of zone groups
- ✓ Better feedback information from principal devices to secondary devices
- ✓ Extended status information on the system, its zones and zone groups.
- ✓ Information when another device is occupying the bus audio channel.
- ✓ Pre-evaluation function of operations before they are executed.

## 2.1 INDICATORS

### 2.1.1 SYSTEM STATUS INDICATORS

The status indicators show at all times the working condition of the equipment or system. They are located in the upper right corner of the equipment.

(a)  : EMERGENCY

Active (on in red colour) when the system is in an emergency operation state (voice alarm). Under this state, the MPS8Z+ may not be able to make live PA live messages, as it has been configured in the system (see the principal system configuration manual, for example NEO).

(b)  : FAULT

Active (on in yellow color) when the system is in a fault state. This indicator is activated automatically after the failure detection of any of the supervised functions.

(c)  : LINK

Active (on in green colour) when the equipment is linked to the system. It will blink while the process of linking to the system or there is a link failure between the equipment and some element of the distributed system. If the problem persists, see chapter 7.2 for resolution.

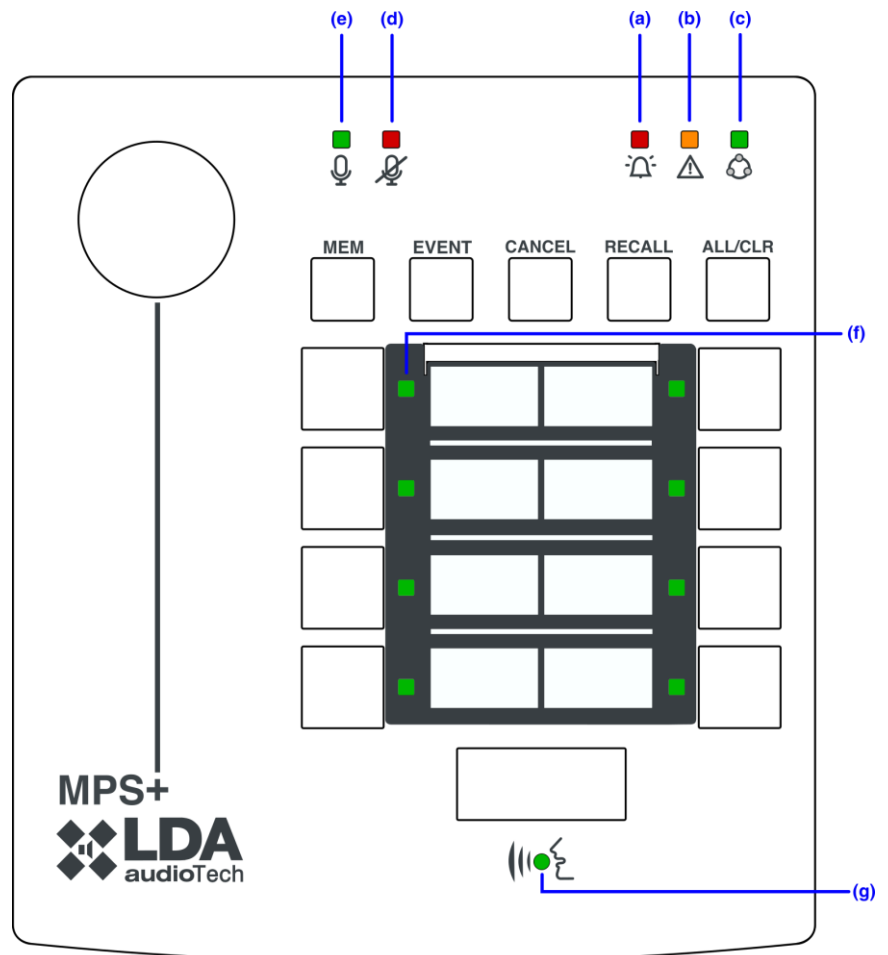

Picture 1: Indicators

## 2.1.2 STATUS INDICATORS OF THE CALL CHANNEL

The status indicators per channel, show at all times their status or operating condition.

(d)  : BUSY

Active (on in red colour) when the call channel is busy by another device with higher priority in the ACSI bus. When during a voice announcement, the call channel is busy by a device with a higher priority, it will light up intermittently, indicating that the call has been cancelled.

(e)  : CONCEDED WORD

Active (on in green colour) when the call channel is assigned and free to be able to make a PA voice announcement. When the pre-warning tone is active on the equipment, it will flash intermittently while it is playing.

Complementary to this indicator, the MPS8Z+ includes an illuminated ring located in the microphone capsule that shows when the user can begin to make the voice message.

(f) ZONE LED "x"

Active (on in green colour) when the memory or zone memories X have been selected.

(g)  : TALK

Active (on in green colour) when the call channel is assigned and free to be able to make a PA voice announcement. When the pre-warning tone is active on the equipment, it will flash intermittently while it is playing.

**NOTE:** this function is available from model version S04 onwards.



## 2.2 CONTROLS

### 2.2.1 ADVANCED FUNCTION CONTROLS

#### (a) "MEM" (MEMORY)

The "MEM" button is located to the left of the upper area of the keyboard. It allows access to the configured zone memories.

#### (b) "EVENT"

The "EVENTS" button is located in the second position from the left side in the upper area of the keyboard. Allows access to the selection of system events.

#### (c) "CANCEL"

The "CANCEL" button is located in the middle of the upper area of the keyboard. It allows cancelling those operations that require confirmation. It also serves as an access key to the configuration functions of the equipment.

#### (d) "RECALL"

The "RECALL" button is located in the second position from the right side in the upper area of the keyboard.

It allows up to three different functions depending on its configuration. These are detailed in chapter 4:

- Recall: allows the repetition of the last voice announcement in the selected zone memories.
- Store & Forward: allows for the delayed broadcast of a message if the system is busy at the time of the call.
- Request: allows checking whether the zones are busy by any audio source at the time of the query.

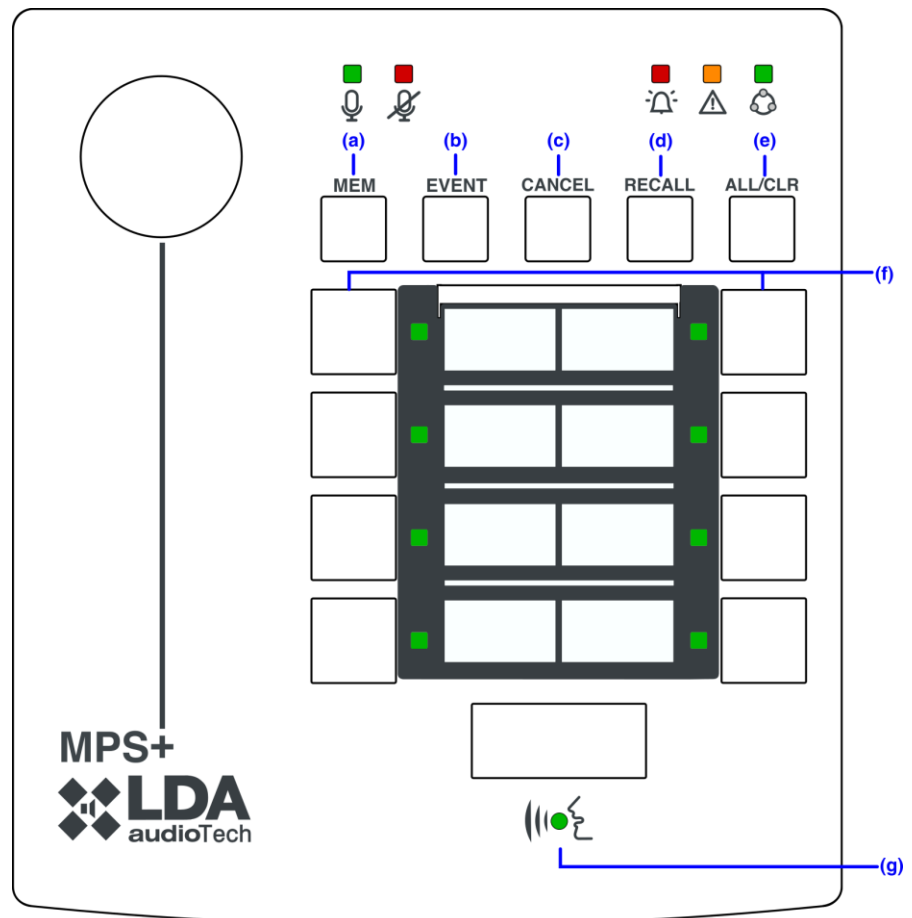

Picture 2: Controls

**(e) "ALL / CLEAR"**

The "ALL / CLEAR" button is located to the right of the upper area of the keyboard. Allows the selection of all available zone memories. When one or more zone memories are selected, by pressing this button it will unselect all.

## **2.2.2 CALL FUNCTIONS CONTROLS**

**(f) ZONE MEMORY**

They are located in the lower half of the microphone desk. They allow the selection of zone memories, and the voice message, one or several simultaneously. When a memory is selected, the memory indicator will be activated.

**(g)  : TALK**

It is located at the bottom of the keyboard, occupying the central area. It allows to request the channel to make the voice announcement call through the selected zone memories. It also acts as a confirmation ("OK") of the operations that require it.

## **2.2.3 DENIED OPERATIONS FEEDBACK**

**(h) BUSY FEEDBACK**

ACSI bus gives additional information to secondary devices when it is given a busy response. MPS8Z+ can be aware and show to the user which zones/groups have any conflict so that it can't talk to them.

This information will be given to the user by a light blinking on the zones/groups that have been told as busy at the same time that the BUSY LED  is active.

Busy zones/groups can be deselected and perform a new talk request, so he can give his message to the available zones.



When the ACSI bus is being used by another device, BUSY LED  will blink to show the state of the bus, the user will be able to avoid cutting some other's message by waiting to make his call when the bus becomes idle again.

If the ACSI bus has been configured with the same priorities for all the microphones, no talk exclusion will ever occur, and this  indication will mean that the microphone won't be able to talk.

**(i) PRESELECTION EVALUATION**

It is possible to evaluate button preselection anytime without making any talk request. This can be useful to check the busy state of the zones it may want to talk to, before making the call.

The RECALL button on the MPS+ will poll the system if the current zone/group selection is available to make a call. In case some of them were occupied by some higher priority audio source, a busy indication will be given to the user, blinking the LEDs on the zones/groups that aren't available.

If all selected zones/groups are available,  LED will blink fast for 3 seconds. Pressing the  button during this period will launch the recall of the stored message. Please note that, if the recall function is disabled or there isn't a recorded message, the MPS+ will show a busy state .

## 2.3 INPUTS AND OUTPUTS

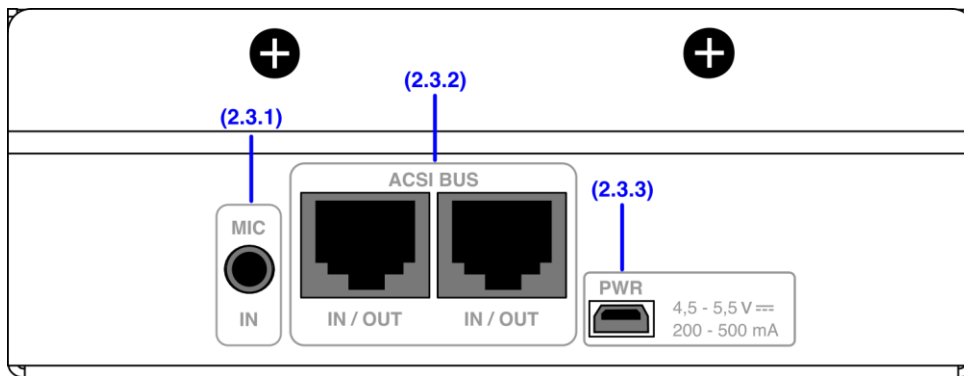

Picture 3: Inputs and Outputs

### 2.3.1 MIC

This input allows you to connect an external microphone or a stereo audio line (see chapter 5.3 for its configuration).

When the external microphone mode is enabled, a mono audio connection will be used where only the left channel of the mini-jack connector is received. In addition, an additional gain level will be applied to adapt the volume of the microphone audio signal.

When using the external line mode, stereo audio will be received, which will be converted to mono internally in the DSP, mixing the left and right channels (L and R). It is recommended to disable the DSA option when using the external line input mode (see section 5.4), as this DSP processing is oriented to adjust voice signals coming from a microphone.

The connection is made via a 3-pin 3.5mm male mini-jack connector.

Mark	Description	Type	Signs	Activation
1	Audio signal left channel	Input	Channel L	Configuration (see 5.3)
2	Audio signal right channel	Input	Channel R	
3	GND	Input	Ground	

Table 1: Input External microphone

### 2.3.2 INPUT / OUTPUT FOR PUBLIC ADDRESS AND VOICE ALARM SYSTEM (ACSI BUS “LOOP”)

The equipment has two connections for distributed elements in Public Address systems. It consists of a line-level audio input plus control signals for connecting up to 32 devices in a 'daisy chain' bus, where each device is connected to the next. Both connections are identical and interconnected. The ACSI bus supplies remote power to the equipment, see chapter 3.

The connection is done through a screened Ethernet T568B Cat 5E or better cable. Maximum connection distance for all the bus is 1000m (3280,84ft).

Mark	Description	Type	Signals	Activation
<b>ACSI BUS</b>	Line level balanced audio. Control and power bus.	Input	Protocol	N/A

Table 2: Bus ACSI connection

**NOTE:** This connection is not compatible with standard Ethernet.

### 2.3.3 AUXILIARY POWER SUPPLY

The equipment has an auxiliary power supply. Emergency voltage is continuous and has a nominal value of 5V. It will be externally supplied through an USB charger, included with the equipment (female miniUSB connector).

Mark	Description	Type	Signals	Activation
<b>POWER USB</b>	Auxiliar power supply input.	Port	USB 1.1	5V DC Max Current: see technicals characteristics (chapter 9)

Table 3: Auxiliar power supply input

Connection is done through a male miniUSB cable, AB type (supplied with the system)

### 2.3.4 PORTS FOR EXPANSION KEYBOARDS

The equipment has two available ports for connecting additional keyboards, one on each side of the unit. Only one of the ports can be used simultaneously.

Mark	Description	Type	Signals	Activation
-	Expansion port	I/O	-	N/A

Table 4: Expansion port

## 3 CONNECTION AND SETTING UP

Before we continue, if you have the MPS8Z+ microphone desk, it is likely that it is already factory configured with the ACSIV2 system.

But, both this version of MPS8Z+ and the previous MPS8Z, support ACSI v1 and ACSI v2 configuration, so how do I know if my MPS has firmware version V1 (ACSIV1) or V2 (ACSIV2)?

First of all, you should know that firmware versions v01.xx correspond to ACSIV1 devices, and firmware versions v02.xx correspond to ACSIV2 devices. However, in order to differentiate them in a simple physical way and to follow the correct manual, the sequence of the status LEDs is not the same when they are switched on, so you should check if when you switch on your MPS:

- The status LEDs flash twice, all at the same time, in which case it is ACSlv2.
- The status LEDs, make a random sequence of power on, in which case it is ACSlv1.

If it is ACSI v1, go to the MPS8Z manual, where the functionalities of this version are described.

If it is ACSI v2, continue reading this manual, as it is focused on this new version.

### 3.1 POWER SUPPLY

The MPS8Z+ is provided with an external power supply of 5V DC A female USB connector, which is connected by a male AB miniUSB cable to a male A USB, also provided. It can be used to supply the equipment or it can also be supplied directly from the ACSI bus. In this case, keep the power supply for later use.

#### 3.1.1 POWER SUPPLY SELECTOR

The equipment has a “PWR” selector that allows you to choose the energy source between local or provided through the ACSI bus.

When the selector is in OFF position, the equipment will be locally supplied by the external charger.

When the selector is in ON position, the MPS8Z+ will be supplied from the ACSI bus. If the external charger is connected, it will switch automatically if the ACSI bus power is interrupted.

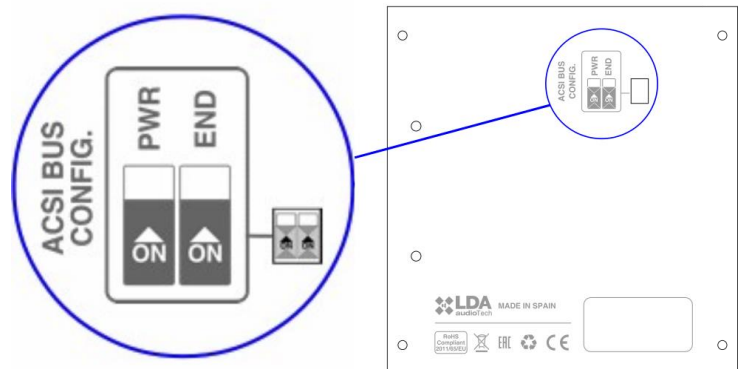

Picture 4: Power supply selector

### 3.2 CONNECTION TO THE SYSTEM (ACSI BUS)

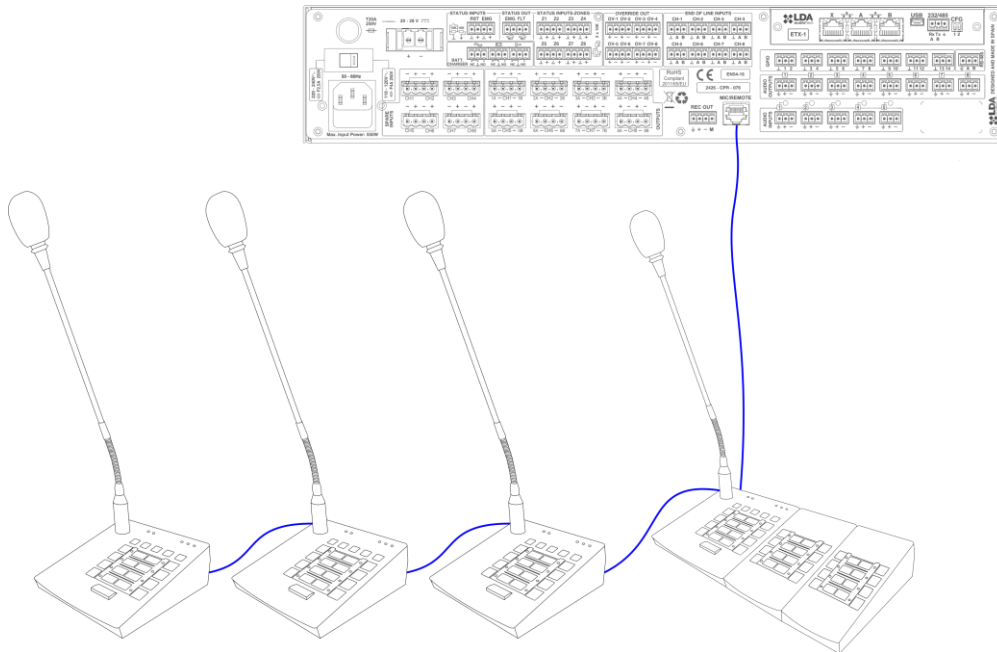

Picture 5: Devices connection in a Public Adress System

The equipment has two connections for the Public Address system. The connection for all the elements is in bus mode. Each device is connected to the previous one, up to 32 devices and a maximum total wiring of 1000m (3280,84ft).

### 3.3 ACSI BUS ADDRESS CONFIGURATION

ACSI devices use one logical address for communications with the public address system. There cannot be two devices on the bus using the same address, this would generate a collision and the behaviour would not be appropriate. By default, in its factory configuration, the MPS8Z+ will be configured with address 1, but it can be set between 1 and 32.



To set the system address in the bus and set the ACSI address of the MPS8Z+, proceed as follows:

- Ensure that the equipment has not got conceded word. The “🔇” indicator will be off.
- Hold the “CANCEL” and “MEM” buttons for at least 3 seconds.
- The access to the address setting will be confirmed by the blink lighting up of the “🔊” and “⚠️” indicators. The set bus address will be indicated by lighting the indicator of the zone memory associated.
- Push the memory selection button whose number corresponds with the desired address. (Remember the address matches the priority) The selection indicator of the corresponding zone memory will light up.
- It is possible to add an offset to set directions from 1 to 32 (in steps of 8). To increase the offset press “ALL/CLR” button and “MEM” to decrease it.
- This offset is indicated with a blinking state of the zone led, as shown in the table below:

No blinking	Offset value = 0	Selecting zones from 1 to 8
Zone 1 blink	Offset value = 8	Selecting zones from 9 to 16
Zone 2 blink	Offset value = 16	Selecting zones from 17 to 24
Zone 3 blink	Offset value = 24	Selecting zones from 25 to 32

**Note:** When the set address and offset coincide on the same LED, priority be given to blinking to indicate the offset. For example, address 9 will be shown with blinking state on the zone 1 LED.

- Press the “” button to confirm, “CANCEL” to cancel the address change.
- The equipment will restart with the new bus address.

If while starting the MPS8Z+ the “”, “” y “” indicators blink simultaneously, there is an address conflict in the ACSI bus with this device. In that case you must change the address.

### 3.3.1 BUS TERMINATOR

The bus terminator selector “END” is located in the upper part of the base of the equipment.

It allows to activate/deactivate the bus terminator. This control must be active when the equipment is in the last position in the ACSI bus.

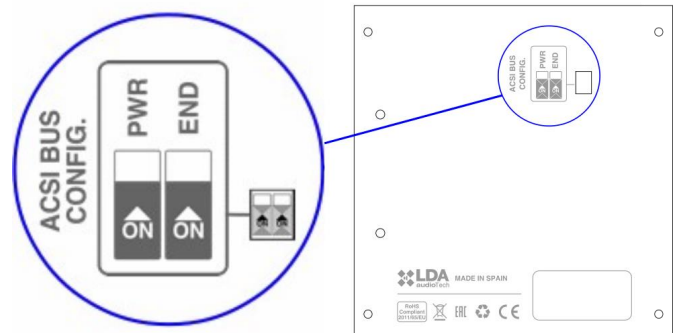

Picture 6: Bus terminator selector

### 3.3.2 ACSI BUS VERSION ERROR DETECTION

Please note that the ACSI v2 is not compatible with its previous version v1. This means that **ACSI v1 and v2 devices cannot work together on the same bus**. The principal device of the bus, e.g. NEO, should be configured to work in one of these modes.

It could happen that an MPS+ v02.xx is connected to an ACSI v1 bus. In this case, the MPS+ is able to detect ACSI v1 traffic and display a specific error to advertise the user of the bus misconfiguration.

This error will be displayed with the alternated blinking of the LEDs  and .



### 3.4 MPS-8K+ EXPANSION KEYBOARDS INSTALLATION

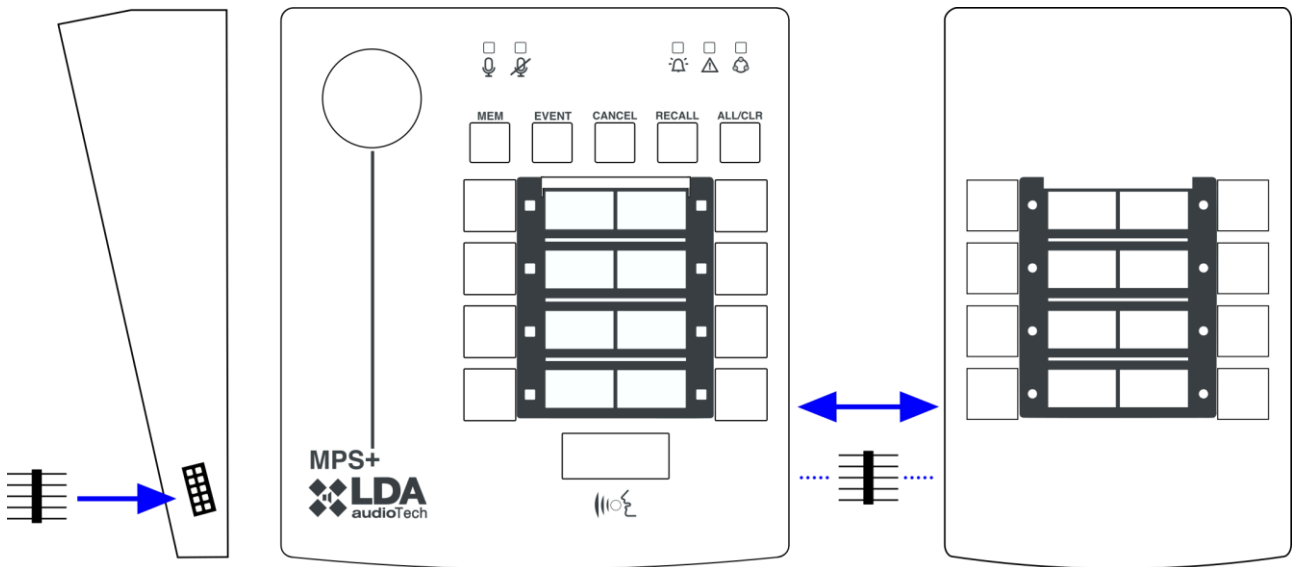

Picture 7: MPS-8K+ Expansion Keyboard Installation

MPS8Z+ paging microphone can attach up to 7 expansion keyboards, each of them with 8 zone selection buttons. In order to connect the expansion keyboards, MPS8Z+ has 1 expansion port, located on the right side of the device. This way, the keyboards can be installed on the right side of the MPS8Z+.

To install the expansion keyboards, please follow the next steps:

- Disconnect MPS8Z+ from the ACSI bus and from the power supply.
- Place the connection adapter (supplied with the expansion keyboard) on the chosen side and connect both the paging station and the expansion keyboard completely till make a full connection.
- Flip over both devices and screw the metal plate at the bottom in order to fix the connection of both devices.

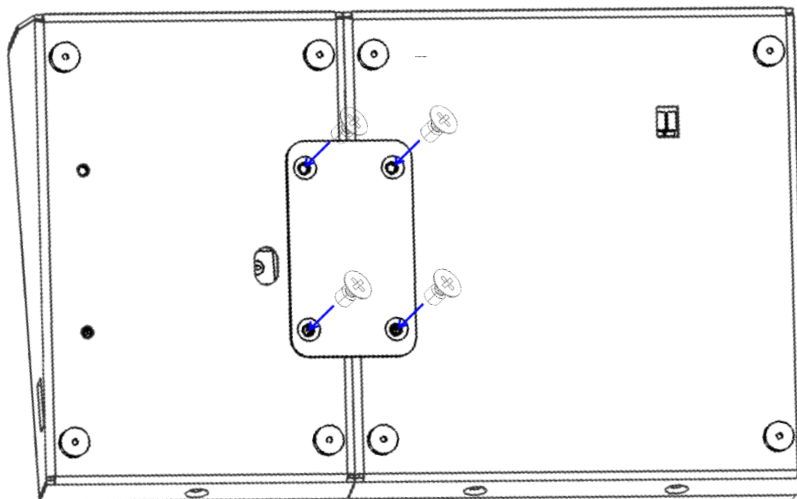

Picture 7.1: MPS-8K+ Expansion Keyboard Installation

- Select the expansion keyboard ID with the corresponding roulette as shown in chapter 3.4.1
- Connect again the MPS8Z+ to the ACSI Bus. By default, the new buttons will adopt the PA/VA System zones as shown in chapter 3.3.

### 3.4.1 KEYBOARD ID

The keyboard ID selection roulette is only available in the expansion keyboards attached to the MPS8Z+. This selection roulette is located at the base of the device in the central part. It allows to select the location of the keyboard within the set of all the attached keyboards. Each keyboard should have a different ID. In a PA/VA System where the Zone Buttons have not been configured (with NEO Configurator), the zone associated to each button will be determined by the ID selected in the roulette. The zone assigned to each button will be by default as follows:

- ID 0: Selection not allowed, by default it will assigned ID 1.
- ID 1: Zones 9-16
- ID 2: Zones 17-24
- ID 3: Zones 25-32
- ID 4: Zones 33-40
- ID 5: Zones 41-48
- ID 6: Zones 49-56
- ID 7: Zones 57-64
- ID 8: Selection not allowed, by default it will assigned ID 1.
- ID 9: Selection not allowed, by default it will assigned ID 1.

### 3.5 BUSY BUS FEEDBACK

The MPS+ can now show when the ACSI bus is busy (some other microphone is currently speaking). This will be shown by a slight flashing of the "🔇" indicator.

Regardless of this indication, the user can make a call if he wishes. The result of this call will depend on the priority set on the system for the MPS+: if it is higher, he can talk, if it is lower, he cannot.

However, the advantage of this indication is that the user will be able to avoid cutting off the message of someone else waiting to make his call when the bus becomes idle again.

If the ACSI v2 bus has been configured with the same priorities for all microphones, conversation exclusion will never occur, and this busy indication will mean that the microphone will not be able to talk.

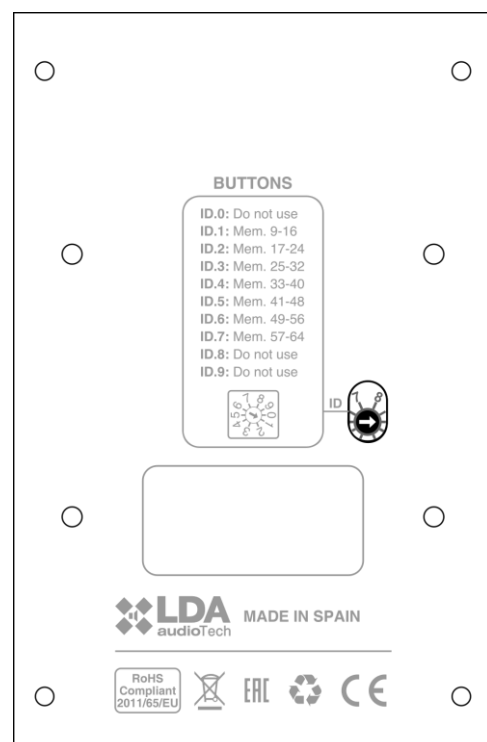

Picture 8: MPS-8K+ Expansion Keyboard ID

## 4 OPERATION DESCRIPTION

### 4.1 POWER ON

Select the power supply origin as shown on 3.1. Connect the power supply cable into 'PWR' (Power) connector located on the back side of the equipment, or directly through the ACSI bus. On the frontal side of the equipment, a check indicators sequence will start. Once the sequence is finished, linking with the system process will start and it will be shown in the corresponding indicator.

When you turn on the equipment for the first time, you must make the typical installation adjustments (see chapter 3).

### 4.2 KEYBOARD LOCK

The MPS8Z+ has an optional feature to lock the keyboard. To configure the key lock, please see section 5.5.

When this feature is activated, the keyboard locks manually or automatically after 60 seconds from the last operation. To lock the keyboard, press the "CANCEL" and "⏏" keys simultaneously. The zone memory indicators will blink once. To unlock the keyboard, press again "CANCEL" and "⏏" keys, the zone memory indicators will blink twice.

If any button is pushed during the key lock, the zone memory indicators will blink two times.

### 4.3 PAGING VOICE ANNOUNCEMENTS

To page a voice announcement, select the zone memories which you want to issue the warning. Their selection indicators will light up. Then push "⏏" key. If the notice channel is available, the "📞" indicator will light up and the equipment will be ready to issue the warning. If the prior notice tone is set, the "📞" indicator will light up intermittently until it is completed. If the channel is not available, the "📞" indicator will light up.

"⏏" key is configured in latch mode by default. It can be configured on the configuration menu 5.1.

By pressing "⏏" button, if any zone was preselected before a talk request, MPS+ will show a 📞 indicator.

### 4.4 ENDING THE CALL WITH THE CANCEL BUTTON

When talk request is configured as "latch", conceded word can be finished by pressing CANCEL, or TALK again, as usual.

## 4.5 ZONE MEMORY SELECTION

To issue a warning, you can click every selection control of the zone memories or use the "ALL/CLR" key. This control will select every single zone. If you want to deselect them, press the desired zone control again or the "ALL/CLR" key if you want to do it with all of them. Zone memory indicators will turn off.

By default, the system zones that are assigned to each MPS8Z+ are matched to the system zones, so in zone memory 1 you can select system zone 1, in memory 2 you can select system zone 2, and so on. The zones assigned to each zone memory button can be configured to the public address system to which your MPS8Z+ is connected. Each zone memory may be associated with a zone in the system or a group of zones. The number of groups and their configuration will depend on the public address system. For example, NEO systems have up to 64 configurable zone groups with very high flexibility. It is also possible to create groups that call all zones in the system from a single memory key.

Zone buttons that do not have any zones or zone groups configured will flash rapidly if pressed, to indicate to the user that their press has been correctly detected, but will not activate or select any memory as they have no associated configuration.

## 4.6 ZONE MEMORY GROUP SELECTION

The unit allows up to 8 zone memory presets to be recorded for user convenience. These 8 memories correspond to the 8 zone memory keys of the MPS8Z+ main unit. The keypad extensions do not have memory for preset groups.

Also, if there is no preset memory configuration stored in any zone button, pressing the MEM button will illuminate the "⓪" indicator for one second to indicate to the user that there is no preset to load.

To select a group, press the "MEM" control, the zones that have memories assigned to them will flash and then one of the configured groups will be assigned to one of the zone selection controls. The zone memories stored in the group will be selected, and their selection indicators will light. To cancel memory selection just press "CANCEL" or "⓪". MPS8Z+ will skip "MEM" menu once passed 10 seconds if no memory was selected.

## 4.7 RECORDING ZONE MEMORY GROUP

The equipment allows to record up to 8 zones memory shortlists for user's comfort. To make the recording follow the next procedure:

- Ensure that the equipment has not conceded word, the "⓪" indicator will be off.
- Press the zone memories you want to be part of the group.
- Hold the "MEM" key for 3 seconds.
- Zone memory keys that have a stored preset will flash.
- Press the zone memory where you wish to store your preset, choosing one of the eight memory keys available on the main keypad.

To cancel this operation just press "CANCEL" or "⓪". MPS8Z+ will skip this status once passed 10 seconds if no memory slot was selected.

## 4.8 DELETE MEMORY PRESELECTIONS

Previously stored memories can be deleted by storing a blank zone preselection in a zone memory, as follow:

1. Unselect all zones.
2. Press “MEM” for 3 seconds, stored key memories will blink.
3. Select the zone memory to delete.

## 4.9 LOCKING OF UNUSED ZONE BUTTONS

MPS+ zone buttons can be configured in the master unit by assigning the ID of the zone or group to which they will call. It is also possible to lock them by setting up an invalid identifier (zero or an out-of-range zone ID). In this case, these buttons will remain disabled so the user will easily realize that they are not bound to any zone or group.

In order to differentiate a button lock from a physical device error, they will flash briefly when pressed, but will not remain selected.







## 4.10 STORE & FORWARD

This function allows the broadcasting of a delayed voice message in case the system is busy at the moment the user wants to make the call. In this case, the MPS8Z+ is able to store the message in its internal memory for later broadcasting once the system is available again. This can be configured in the settings menu 5.6.





When enabled, the flow will be as follows:

- If the MPS+ is given a denial response from the master it will first show which zones/groups have been rejected for a while, and then it will pass to record the message.
- During the recording status the user must give his voice message to the microphone, it's being stored in the internal memory. This operation can be aborted anytime with the cancel button. Please be aware that the MPS+ is able to record messages up to 45 seconds. If this time is exceeded, the microphone will end the recording and pass to waiting status automatically.
- After the message recording has finished, the MPS8Z+ will go into waiting status. During this mode, the device will perform periodically a talk request to the master until it gets a positive response. This operation can also be aborted anytime with the cancel button. There is a timeout of 5 minutes for this state, if the system remains busy for more than this period, the message playback will be automatically aborted. Anyway, the user can recover this recorded message with the RECALL function when the system be available. **Please note that the message will also be aborted in case the system enters on emergency state.**

**MPS8Z+ LED indications** on each new status:

- Recording status: the  LED will be steady on, and the  LED will blink very lightly. The LED on the microphone capsule will be active.
- Waiting status: the  and  LEDs will blink slowly and alternately (green-red-green-red...).
- Playing stored message: the  will be active with a very light blinking (it will be active the 80% of the time). The LED on the microphone capsule will be off (the message is not live, was previously recorded).
- No memory available: When Recall or Store & Forward are enabled, the microphone will give a  busy response in case its internal memory is not still available to record the message. Please be aware that this internal memory must be erased between two consecutive speeches, so the microphone needs some time to do that (typically about 20/30 seconds). If the user makes two consecutive calls in a short time period, he could get this  busy response from the microphone.

#### 4.11 RECALL

The system has a memory to record up to 45 seconds of the last voice message, allowing the last broadcast message to be replayed at the user's request. To repeat the message issued, select the zones you want to issue the message in, then press "RECALL" and " " indicator will start blinking. Confirm by pressing the " " button before 3 seconds. If the notice channel is available, the " " indicator will light up, otherwise, the " " indicator will light up.

To cancel the recall, press "CANCEL" button and " " indicator will turn off.

If there is any voice announcement stored, pressing "RECALL" will illuminate the red  LED for ONE second.

This can be configured in the settings menu 5.6.

NOTE: If different messages are issued before 15 seconds, the recording may not be done to protect the memory. In this case when you press "RECALL" key, " " indicator will automatically light up showing there is no recorded message.

#### 4.12 BUSY ZONE/GROUPS REQUEST

It is possible to check the status of the zones or groups assigned to the device as long as the Recall and Store & Forward functions are disabled. This can be configured in the settings menu 5.6.

After pressing the "RECALL" key, the zones or groups of zones busy by any type of audio source will start blinking.

If all the zones remain off, it means that no zone or group is busy at that time.

This function can be stopped at any time by pressing the "CANCEL" or " " button.

## 4.13 SYSTEM EVENT

The desktop microphone MPS8Z+ allows to launch system events, such as pre-recorded messages issuance, sound sources assignment, zone volume control, etc. To assign system events to zone memory selection buttons of the MPS8Z+, see the software configuration User's Manual of the system that your MPS8z+ is connected to (for example, NEO system)

### 4.13.1 LAUNCHING SYSTEM EVENTS

To launch a system event press the "EVENT" control. The "🔊" and "🔇" indicators will light up simultaneously. Then select the desired event by pressing the zone memory button where it is assigned. Then push "🔊" to confirm or "CANCEL" to cancel. If the system has been able to launch the event, the "🔊" indicator will blink twice.

It is possible to send a "multi-trigger" command in order to tell the master more than one trigger to be launched simultaneously.





## 4.14 POWER-SAVING MODE

MPS+ includes a power-saving mode in order to reduce the overall system power consumption. By default, it will be active in the factory settings of the MPS+. It can be configured on the configuration menu 5.5.

When enabled, all zone LEDs will turn off after 60 seconds of inactivity. Anyway, the user preselection will remain untouched and, if desired, a call can be done by simply pressing the "🔊" button. Pressing any button will exit this power-saving state.

## 5 MPS8Z+ PERFORMANCE-BASED CONFIGURATIONS

It is possible to configure MPS8Z+ Paging Microphone according to several operation parameters. To access the configuration mode of the device, follow these steps:

- Make sure the device does not have conceded word. The “” light should be off.
- Keep pressed the button “CANCEL” and the button “EVENT” for at least 2 seconds.
- When you are in the configuration mode, the “” and “” lights will be blinking.
- Configure the parameters as shown in chapter 5.1 to 5.7.
- Press the button “” to confirm, or “CANCEL” to cancel any change.
- The device will restart with the new configuration.







Ilustración 9: Zone memory buttons

### 5.1 CONFIGURATION OF TALK BUTTON

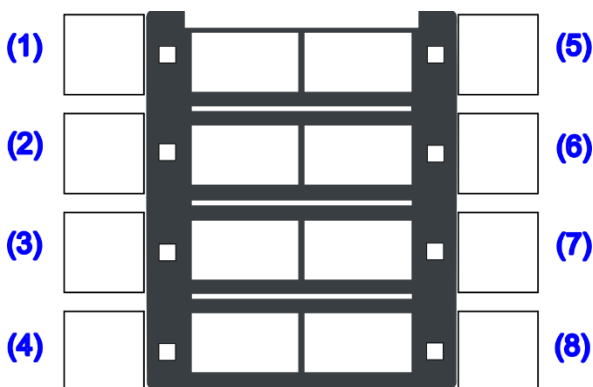
The zone 1 button enables/disables the “latch” function for the “” button. When this option is enabled, the zone 1 light will remain on. When this function is enabled, pressing once the “” button will keep the microphone open until the “” button is pressed again.

To confirm the new configuration, press “”, to cancel, press “CANCEL”.

### 5.2 CONFIGURATION CHIME

The zone 2 button enables/disables the pre-talk chime. When this function is enabled (light on), a chime will be played before the microphone is open to talk.

To confirm the new configuration, press “”, to cancel, press “CANCEL”.

### 5.3 CONFIGURATION OF EXTERNAL MICROPHONE

Pressing the zone 3 memory button sets the configuration of the external microphone/line input (see section 2.3.1).

There are three configuration options:

- LED OFF: External microphone input disabled. The gooseneck microphone included with your MPS8Z+ will work.



- LED ON: External microphone mode enabled. MIC input configured for single-channel audio. The gooseneck microphone of your MPS8Z+ will be disabled.
- BLINK LED: External line mode activated. MIC input configured for stereo audio. The gooseneck microphone of your MPS8Z+ is disabled. In this mode the DSA setting will be disabled by default, it is recommended not to use it with audio signals other than live voice.

To confirm the new configuration, press “”, to cancel, press “CANCEL”.

#### 5.4 CONFIGURATION DSA FUNCTION

The zone 4 button enables/disables the DSA function. DSA (Digital Sound Adjustment) is a Digital Voice Processing that automatically adjust the gain of the voices of different users. When this function is enabled, the zone 4 light will remain on.

To confirm the new configuration, press “”, to cancel, press “CANCEL”.

#### 5.5 CONFIGURATION OF LOCK & POWER-SAVING

The zone 5 button enables/disables the keyboard lock and power-saving. When this function is enabled (light on), the MPS8Z+ will be automatically locked or turn off after 1 minute since the last operation on the microphone. In order to unlock the microphone, you will need to press the buttons “CANCEL” and “” simultaneously.

This behaviour can be configured in the 5th option of the configuration menu, together with the key-lock functionality, as shown below:

- LED OFF: power-saving enabled, key-lock disabled.
- LED BLINK: power-saving and key-lock both enabled.
- LED ON: power-saving and key-lock both disabled.

To confirm the new configuration, press “”, to cancel, press “CANCEL”.

#### 5.6 CONFIGURATION OF STORE & FORWARD and RECALL

By default, RECALL and Store & Forward will be disabled. The 6th option on the configuration menu will be used to configure these functionalities as described below:

- LED OFF: Recall and Store & Forward are both disabled.
- LED BLINK: Recall is active. Talk timeout of 45 seconds.
- LED ON: Recall and Store & Forward enabled. Talk timeout of 45 seconds.

To confirm the new configuration, press “”, to cancel, press “CANCEL”.

## **5.7 CONFIGURATION OF OUTPUT VOLUME**

The output volume level of the MPS8Z+ is configured with Zone 7 and Zone 8 buttons. Press Zone 7 to increase the volume level and Zone 8 to decrease volume level. Each time the button is pressed, the corresponding zone light will be shortly on. When the volume level is at the maximum, the zone 7 light will remain on. When the volume level is at the minimum, the zone 8 light will remain on.

To confirm the new configuration, press “”, to cancel, press “CANCEL”.

## **5.8 PERMANENT STORAGE**

MPS8Z+ will save this configuration in its internal memory, so this configuration will be recovered after a new reboot.

## **5.9 FACTORY RESET**

If the user wants to delete all stored configurations, it can be done through a factory reset of the device pressing buttons “CANCEL”, “EVENT” and “MEMORY” for 5 seconds.

## 6 UPDATE

If a firmware update is required, confirm that the image of the supplied update matches your model. If the equipment has expansion keyboards connected, it is not necessary to disconnect them. Proceed as follows:

- Connect the equipment to your PA/VA system.
- Follow the instructions from your PA/VA system regarding the ACSI device firmware upgrade.
- During the firmware upgrade of your MPS8Z+, the Emergency and Fault status indicators, as well as the Talk Granted and Busy indicators will flash simultaneously, while the System Link indicator will remain lit.

## **7 FAULT RESOLUTIONS**

### **7.1 THERE IS NO LINK WITH THE SYSTEM**

The system will indicate link fault when it detects that the transmission route has a short circuit or is disconnected.

Check that the equipment where the ACSI bus is connected (NEO Controller) is working properly, try connecting just one unit in the ACSI bus with a short cable to discard problems in the cable.

Check that only the last element in the bus has the option "END of Bus" activated, according to chapter 3.3.1.

Connect the auxiliary power supply included with the equipment in case the MPS8Z+ is powered directly from the ACSI bus.

Check that the connection between the equipment and the system was correctly performed as indicated in chapter 3.3.1.

Factory Reset the unit (the equipment must be configured again). In this case, press simultaneously the buttons "CANCEL", "EVENTS" and "MEMORY" for 5 seconds. The equipment will restart. Configure the address accordingly 3.3.

If this procedure does not work, disconnect the unit from the ACSI bus and contact LDA's Support Department. Once the unit is removed, if there are more units connected in the bus, connect the inputs and outputs lines of the ACSI bus in order to keep the system functioning in normal operation.

### **7.2 STATE LED INDICATORS BLINK SIMULTANEOUSLY**

The system will indicate address fault in the ACSI bus when there are two or more units with the same address.

Confirm that the unit's address is correct, in order to do this, follow the steps indicated in chapter 3.4.

Factory Reset the unit (the equipment must be configured again). In this case, press simultaneously the buttons "CANCEL", "EVENTS" and "MEMORY" for 5 seconds. The equipment will restart. Configure the address accordingly 3.3.

If this procedure does not work, disconnect the unit from the ACSI bus and contact LDA's Support Department. Once the unit is removed, if there are more units connected in the bus, connect the inputs and outputs lines of the ACSI bus in order to keep the system functioning in normal operation.

### **7.3 FLT AND LINK LEDS BLINK ALTERNATELY**

The system will indicate that the ACSI bus is set to an incorrect version, ACSI v2 is not compatible with its previous version v1, so devices with different ACSI bus versions cannot work together. The bus must be configured correctly in the public address system (see section 3).

### **7.4 NO LED INDICATOR IS ON**

If this is the case, probably there is a problem in the power supply.

If the unit is being powered over the ACSI bus, disconnect the unit from the bus and connect the auxiliary power supply included with the equipment. The unit will then start the test of the led light indicators.

If the problem remains, or if it is connected to the auxiliary power supply and the bus simultaneously, follow the steps indicated in chapter 7.1 and if you need, you can contact LDA's support department.

### **7.5 THE VOICE ANNOUNCEMENT IS VERY LOUD/LOW.**

If this situation is similar in all the elements connected to the bus, check the configuration of the equipment where it is connected (NEO).

In case there is a specific MPS8Z+ unit, check the configured volume according to chapter 5.7.

Factory Reset the unit (the equipment must be configured again). In this case, press simultaneously the buttons "CANCEL", "EVENTS" and "MEMORY" for 5 seconds. The equipment will restart. Configure the address accordingly 3.3.

If this procedure does not work, disconnect the unit from the ACSI bus and contact LDA's Support Department. Once the unit is removed, if there are more units connected in the bus, connect the inputs and outputs lines of the ACSI bus in order to keep the system functioning in normal operation.

### **7.6 IS NOT POSSIBLE TO HEAR THE VOICE ANNOUNCEMENT**

Check that the output volume configured in the equipment is correct according to chapter 7.5.

If the problem remains, activate the gong signal according to chapter 5.2. Perform a call and check that the gong signal can be heard correctly. If this is the case, the microphone's gooseneck might had been damaged. Contact LDA's Support Department/RMA and ask for a replacement.

You can keep using the equipment while the gooseneck is being replaced, by using an external microphone and following the steps of chapter 5.3.

If the gong signal does not sound, perform a Factory Reset (the equipment must be configured again). In this case, press simultaneously the buttons "CANCEL", "EVENTS" and "MEMORY" for 5 seconds. The equipment will restart. Configure the address accordingly 3.3.

If this procedure does not work, disconnect the unit from the ACSI bus and contact LDA's Support Department. Once the unit is removed, if there are more units connected in the bus, connect the inputs and outputs lines of the ACSI bus in order to keep the system functioning in normal operation.

### **7.7 THE EXPANSION KEYBOARD DOES NOT ADDRESS THE SELECTED ZONES.**

If when pressing the memory button several zone memory indicators of different keyboards are switch on, the identifier of one keyboard is not correct, or is the same as other unit. Check the identifier according to chapter 3.4.

If the problem is still present, check the connection between the MPS8Z+ and the expansion keyboard, as indicated in chapter 3.4.

If previous actions do not solve the problem, perform a Factory Reset (the equipment must be configured again). In this case, press simultaneously the buttons "CANCEL", "EVENTS" and "MEMORY" for 5 seconds. The equipment will restart. Configure the address accordingly 3.3.

If this procedure still does not work, disconnect the unit from the ACSI bus and contact LDA's Support Department. Once the unit is removed, if there are more units connected in

the bus, connect the inputs and outputs lines of the ACSI bus in order to keep the system functioning in normal operation.

### **7.8 THE EXPANSION KEYBOARD DOES NOT SWITCH ON**

If when pressing the memory button from one or several keyboards their led light indicators are not on, there might be a fault in one of the keyboards.

Check the connection between the MPS8Z+ and the expansion keyboard, as indicated in chapter 3.4.

If the problem is not solved, disconnect the power supply from the unit for several minutes and check that each keyboard is working from the first to the last of them. Disconnect the first keyboard that is not switched on and connect the rest to the MPS8Z+. If necessary, re-configure the address following chapter 18 and the content of each zone through the System's Configuration software. If the problem is not solved, contact the Support Department.

## 8 MAINTENANCE INDICATIONS

The unit requires a reduced periodic maintenance.

The periodicity of the maintenance must be adjusted according to the conditions of the installation. At least, it is recommended to establish a maximum of 1 year period.

Warnings:

- Use only a soft cloth that does not create fluff.
- Disconnect the unit from any external power supply.
- Disconnect all external devices.
- Keep the product away from any liquid.
- Do not use aerosols, solvents or abrasive substances.
- Do not spray any cleaner directly on the appliance.

Operations:

- Clean the equipment with a damp cloth.
- Clean the air inlets and outlets of the equipment with a vacuum cleaner.
- Check the equipment connections.

## 9 TECHNICAL SPECIFICATIONS

Model	MPS8Z+
Power supply	5V DC, 1 x miniUSB type AB.
Power consumption MPS8Z+	230 mA max.
Power consumption Expansion Keyboard	40 mA max.
Frequency response	200- 15000 Hz (+/-2dB).
Signal to noise ratio	R> 98dB, A-weighted.
Sensitivity	-43 dB (1KHz)
Direccional axis	Axial with hipercardioid polar diagram response.
Kind of transducer	Condenser.
DSP	Integrated. 48 kHz, 24 bits – 172 MIPS.
External Microphone input	1 x Unbalanced audio 15mV, 47 K $\Omega$ , 3Pin, miniJack 3,5mm type, for dynamic microphone.
ACSI Bus	2 x ACSI ports identical: Balanced audio 1Vp, 0,707Vrms. 10 K $\Omega$ , RJ-45 female, Total legth: 1000m. / 3280ft.
Expansion ports	2 x Pin grid of 2 rows x 5 female contacts.
Indicators	State: Emergency/ Fault. Link. Busy, Busy Line, Conceded word and zone selected. Gooseneck includes illuminated ring for conceded word.
Buttons	3 buttons for special functions: Memory, Events and Cancel. Re-call button, Selection / deselection button of all zones. 8 zone-memory buttons. 1 Talk button.
Functions	Dingdong, re-call, zone-memory,zone groups, store & forward, volume control, DSA (Dynamic Sound Adjustment), activation of events. Addressing up to 512 zones of the system.
Gooseneck length	450mm / 17,72"
Dimensions without gooseneck (W x H x D)	126 mm x 53 mm x 139 mm / 4,96 " x 2,08 " x 5,47 "
Operating Conditions	-5 °C to +45 °C / 23 °F to 113 °F 5% to 95% Relative Humidity (no condensation)
Finish	Front: Fe, Grey RAL 7042 Base: Fe, Black RAL 9005
Weight	0,73 Kg / 16,13 lb
Accessories for MPS8Z	1 x miniUSB AB male to USB A male cable 1 x USB power supply with connector Type C (EU) 1 x Anti-pop 1 x zonal sheet
Expansion keyboar accessories	1 x expansion port adapter 2 x 5 pins male-male 1 x union accessory to MPS8Z+ 4 x Countersunk screws (3 x 5 mm) 1 x zonal sheet



