

LS-51T

Ref: LDALS51TWS03

The LDA LS-51T is a high-performance two-way acoustic box composed of a 5" woofer and a 1" tweeter. It incorporates a high quality high-pass filter that allows a high sensitivity or sound pressure level without the need of much power.

The soft line design allows their installation in any architectural space. The entire LS range of LDA is made of halogen-free ABS plastic and low resonance. In addition their grille is metallic and acoustically transparent. Therefore, quality, robustness and functionality are guaranteed at all times.

Installation is very easy thanks to the design of their fixing brackets, without the need for specific tools. The included brackets allows an horizontal or vertical installation, and an orientation of 120° with respect to their vertical axis.



Features LS-51T:

- 2 way acoustic box. 5" woofer and 1" tweeter
- High output: 89 dB (1W, 1m).
- ABS enclosure and acoustically transparent metallic grille
- Excellent quality of voice and music transmission.
- Colours: white RAL9003
- Power transformer for 70 / 100V speakers lines
- Power taps selector.

Technical specifications:

Model	LS-51T
Reference	LDALS51TWS03
Power	30W RMS
Frequency response	200Hz – 18KHz. (+/- 10dB)
Sensitivity	89dB +/- 3dB (1W, 1m)
Speaker impedance	8 ohm
Dispersion	90° horizontal / 80° vertical
Colour	White (RAL 9003)
IP protection grade	IP54
Transformer 70 V / 100 V	30W, 15W, 7.5W, 3.75W @ 100V 15W, 7.5W, 3.75W, 1.9W @ 70V
Connection	Cable
Speaker	5" woofer and 1" tweeter
Bracket (optional)	Adjustable with wall or ceiling fixing
Dimensions (width x height x depth)	162 x 242 x 182 mm
Weight	2,5 Kg

Additional information:

Frequency response:

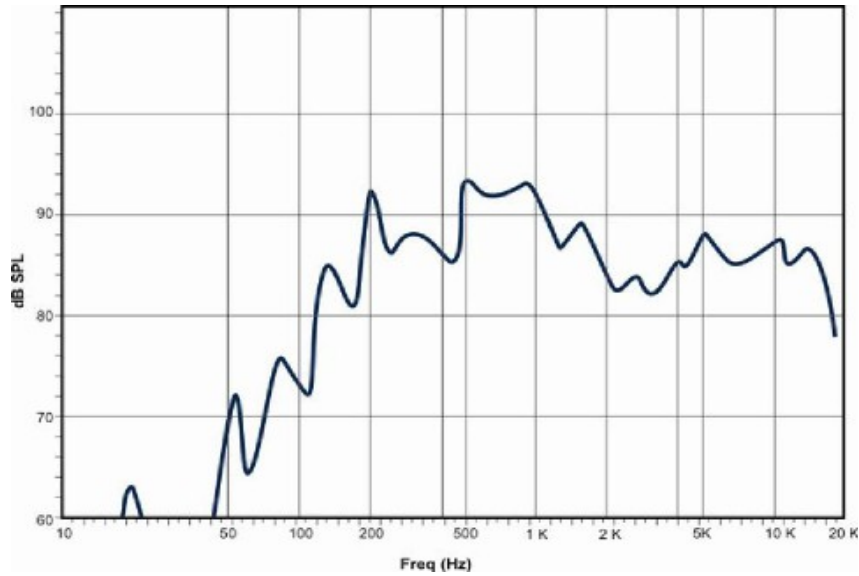

Polar diagram:

Frequency: 1 KHz

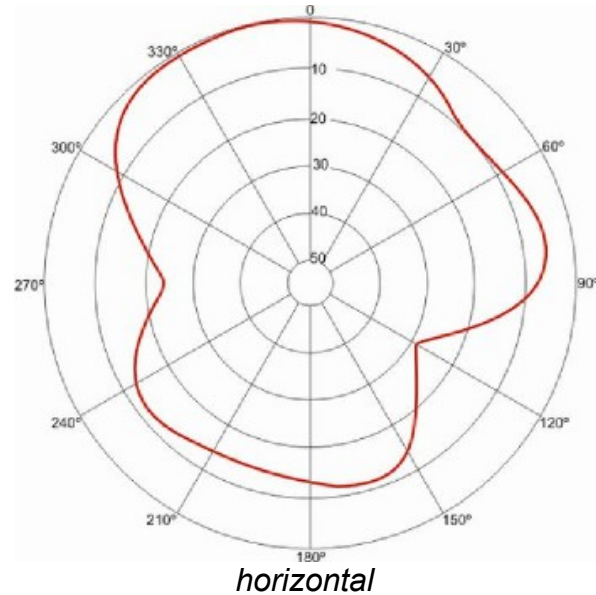
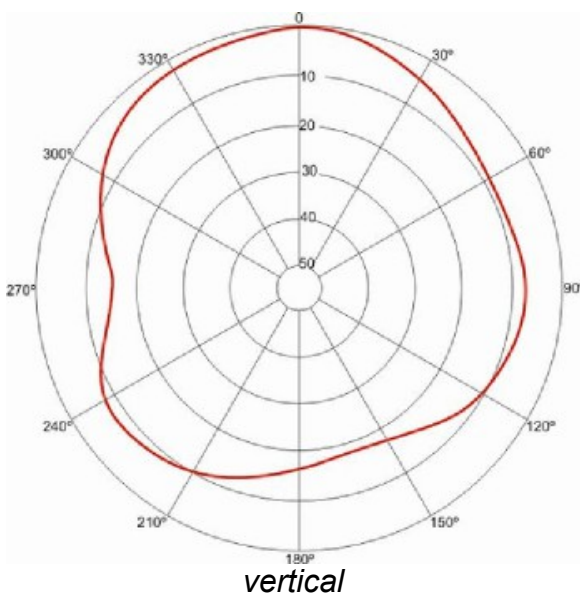

LS-51T

Ref: LDALS51TWS03

Mechanical drawings:

Dimensions in mm

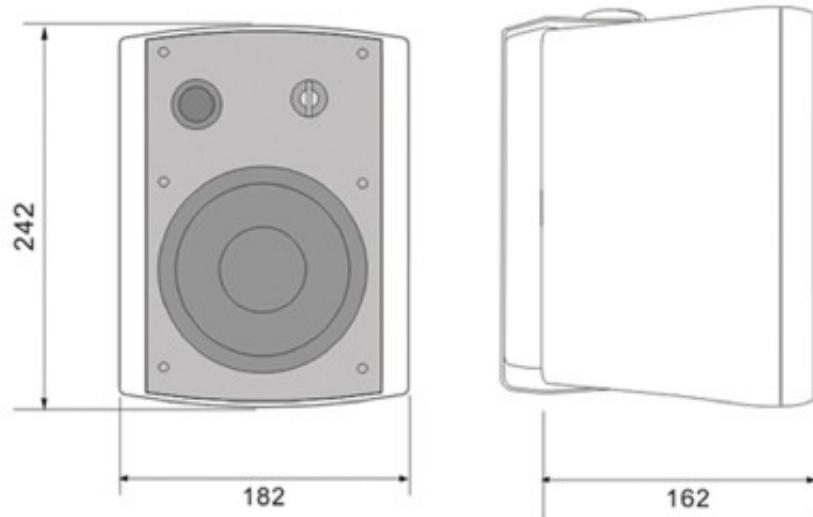

Power taps selector:

Power taps selection for 70/100V lines

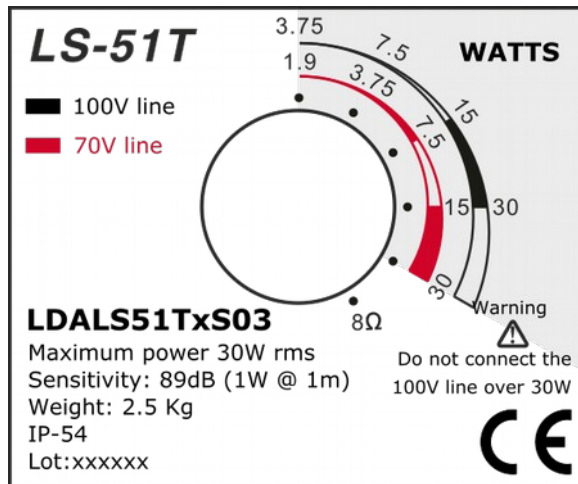

SPECIFICATIONS FOR ENGINEERS AND ARCHITECTS

The LDA professional acoustic box model LS-51T consists on a 5" woofer and a 1" tweeter, connected in parallel via a high-pass filter. This allows the connection to 70V and 100V lines by impedance transformer or direct connection to 8 ohms lines. Its frequency response range is between 200Hz and 18KHz with a sensitivity of 89dB measured at 1W, 1m.

It includes a power selector that allows to choose between different taps in the impedance transformer. This way, for 70V lines the following power taps can be selected: 1.9, 3.75, 7.5 15 and 30W. While for 100V lines these other power taps can be selected: 3.75, 7.5, 15 and 30W. It also allows the use in low impedance lines including an 8 ohm tap selector.

A mounting bracket is included and allows the installation of the loudspeaker either horizontally or vertically, being its dispersion angle of 90° or 80° respectively. The box is made of ABS with acoustically transparent metallic grille and a weight of 2.5Kg. It is available in white colour (RAL9003).

The shape of the box is a 1/6 part of a cylinder. The loudspeaker comes with an adjustable U-shaped bracket and can rotate up to an angle of 90°. Adjustment of the orientation may be made without any specific tools. Bracket fixings includes manually adjustable bolts and grooved surface.

The product fulfills the CE marked.

Warranty	2 years
Product Code	LDALS51TS03

Sound tests:

1. Power

Pink noise is introduced and amplified trough the whole band width obeying the standard IEC60268-5. If the maximum power of the speaker is reached, the noise is cut. Then, the speaker is checked. It must not present visible damages or loss of features after 100 hours of working.

2. Sensitivity, frequency range and impedance.

It is introduced several sinusoidal impulses which have different frequency to 1W of power level from the nominal impedance of the speaker. The average sound pressure level (dB-SPL) is measured to 1 meter of distance with regard to the speaker in a anechoic environment.